

INSTRUCTIONS - INSTRUCTIONS INSTRUCTIES - ANLEITUNG



Rev. A

Contractor Airless Spray Gun; Pistolet pulvérisateur sans air Contractor; Contractor airless spuitpistool; Contractor Airless Spritzpistole

3600 psi (248 bar, 24,8 MPa) Maximum Working Pressure
Pression de service maximum 3600 psi (248 bar, 24,8 MPa)
Maximum werkdruk 3600 psi (248 bar, 24,8 MPa)
Zulässiger Betriebsüberdruck 3600 psi (248 bar, 24,8 MPa)

243282, A

HandTite[®] Tip Guard, 517 RAC[®] 5 SwitchTip[®]; 2-finger trigger
Garde HandTite[®], buse 517 RAC[®] 5 SwitchTip[®]; gâchette de 2 doigts
HandTite[®] tipbeschermer, 517 RAC[®] 5 SwitchTip[®]; 2-vinger trekker
HandTite[®] Düsenschutz, 517 RAC[®] 5 Umkehrdüse; 2-Fingerabzug

235990, C

Standard (nonreversing) Dripless[®] Tip Guard; 4-finger trigger. No spray tip; order separately
Norme (non réversible) Garde-buse Dripless[®]; gâchette de 4 doigts. Pas de buse; commande séparément
Standaard (niet omkeerbare) Dripless[®] tipbeschermer; 4-vingertrekker. Zonder spuittip; afzonderlijk te bestellen
Standardmäßiger (nicht umkehrbarer) tropffreier Düsenschutz; 4-Fingerabzug. Ohne Spritzdüse; separat zu bestellen

217593, E

Standard (nonreversing) Dripless[®] Tip Guard. No tip; order separately
Norme (non réversible) Garde-buse Dripless[®]. Pas de buse; commande séparément
Standaard (niet omkeerbare) Dripless[®] tipbeschermer. Zonder spuittip; afzonderlijk te bestellen
Standardmäßiger (nicht umkehrbarer) tropffreier Düsenschutz; 2-Fingerabzug. Ohne Spritzdüse; separat zu bestellen

824950, A

HandTite[®] Tip Guard, 517 RAC[®] 5 SwitchTip[®]; 2-finger trigger
Garde HandTite[®], buse 517 RAC[®] 5 SwitchTip[®]; gâchette de 2 doigts
HandTite[®] tipbeschermer, 517 RAC[®] 5 SwitchTip[®]; 2-vinger trekker
HandTite[®] Düsenschutz, 517 RAC[®] 5 Umkehrdüse; 2-Fingerabzug

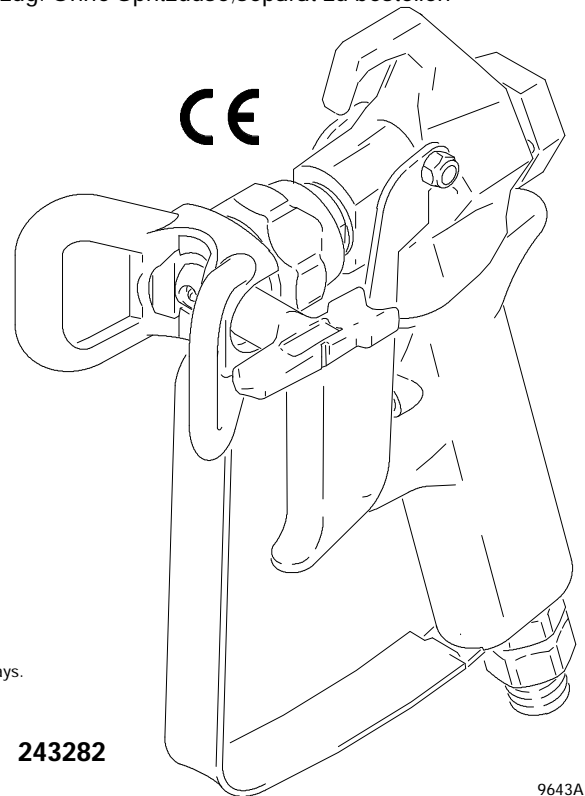

All models not available in all countries.
Tous les modèles ne sont pas disponibles dans tous les pays.
Niet alle modellen zijn in alle landen leverbaar.
Nicht alle Modelle sind in allen Ländern verfügbar.

GRACO N.V.; Industrieterrein — Oude Bunders;
Slakweidestraat 31, 3630 Maasmechelen, Belgium
Tel.: 32 89 770 700 - Fax: 32 89 770 777
ECOPYRIGHT 1999, GRACO INC.

⚠ WARNING

Fire and explosion hazard: Solvent and paint fumes can ignite or explode.

To help prevent a fire and explosion:

DUse in an extremely well ventilated area.

DEliminate all ignition sources; such as pilot lights, cigarettes and static arcs from plastic drop cloths. Do not plug or unplug power cords or turn lights on or off in spray area.

DGround Sprayer, object being sprayed, paint and solvent pails.

DHold gun firmly to side of grounded pail when triggering into pail.

DUse only conductive airless paint hose.

DDo not use 1,1,1-trichloroethane, methylene chloride, other halogenated hydrocarbon solvents or fluids containing such solvents in pressurized aluminum equipment. Such use could result in a chemical reaction, with the possibility of explosion.



⚠ MISE EN GARDE

Risques d'incendie et d'explosion: Les vapeurs de solvant et de peinture peuvent s'enflammer ou causer une explosion.

Pour empêcher tout incendie et explosion:

DN'utiliser ce matériel que dans des locaux extrêmement bien aérés.

DEliminer toutes les sources de feu, comme les veilleuses, cigarettes et les arcs statiques provenant de bâches plastique. Ne pas brancher ou débrancher de cordon électrique ou allumer ou éteindre la lumière sur un site de pulvérisation.

DRaccorder le pulvérisateur, l'objet à peindre et les seaux de peinture et de solvant à la terre.

DAppuyer le pistolet contre le côté du seau mis à la terre quand on pulvérise dans le seau.

DN'utiliser que des flexibles de peinture conducteurs sans air.

DNe jamais utiliser de trichloroéthane-1,1,1, de chlorure de méthylène, d'autres solvants à base d'hydrocarbures halogénés ni de fluides contenant de tels solvants dans une unité sous pression en aluminium. Cela pourrait provoquer une réaction chimique avec risque d'explosion.

Fluid injection and high pressure hazard: High pressure spray or leaks can inject fluid into the body.

To help prevent injection, always:

DEngage trigger safety latch when not spraying.

DKeep clear of nozzle and leaks.

DNever spray without a tip guard.

DDo **PRESSURE RELIEF** if you stop spraying or begin servicing sprayer.

DDo not use components rated less than sprayer *Maximum Working Pressure*.

DNever allow children to use this unit.

DBrace yourself; gun may recoil when triggered.

If high pressure fluid pierces your skin, the injury might look like "just a cut". But it is a serious wound! Get immediate medical attention.

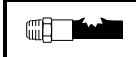

Risques d'injection, haute pression danger: Une pulvérisation ou des fuites à haute pression peuvent provoquer une injection de produit dans le corps.

Pour éviter toute injection, toujours:

DVerrouiller la gâchette à chaque arrêt de la pulvérisation.

DSe tenir à l'écart de la buse et des fuites.

DNe jamais se servir du pistolet pour pulvériser sans une protection de buse.

DEffectuer une **DÉCOMPRESSION** à chaque arrêt de la pulvérisation ou avant tout entretien.

DNe pas utiliser d'éléments prévus pour une pression inférieure à la *pression de service maximum du pulvérisateur*.

DNe jamais permettre à des enfants d'utiliser cet appareil.

DCroisillon vous-même; le pistolet peut reculer une fois déclenché.

Si du liquide sous haute pression est injecté sous la peau, la blessure peut avoir l'apparence "d'une simple coupure", mais c'est en fait une blessure sérieuse! Consulter un médecin immédiatement.

⚠ WAARSCHUWING

Gevaar van brand en explosie: Dampen van oplosmiddel en verf kunnen tot ontbranding komen of exploderen.

Om brand en explosie te voorkomen:

DWerk alleen in zeer goed geventileerde ruimten.

DElimineer alle ontstekingsbronnen; denk aan waakvlammen, sigaretten en statische vonken van een dekkleed of afdekplastic. Steek geen stekker in een stopcontact en haal geen stekker uit een stopcontact in de ruimte waar gespoten wordt.

DAard het spuittoestel, het te spuiten voorwerp, en de emmers met verf en oplosmiddel.

DHoud het pistool stevig tegen de zijkant van een gearde emmer gedrukt terwijl u in de emmer spuit.

DGebruik alleen gearde slangen voor airless spuiten.

DGebruik in aluminium apparatuur onder druk geen oplosmiddelen of spuitvloestoffen die 1,1,1-trichloorethaan, methyleenchloride of andere gehalogeneerde koolwaterstoffen bevatten. Dit kan namelijk leiden tot chemische reacties, met kans op ontploffingen.



⚠ WARNUNG

Brand- und Explosionsgefahr: Dämpfe von Lösemitteln und Lacken können sich entzünden oder explodieren.

Durch folgende Punkte kann die Brand- und Explosionsgefahr verringert werden:

DGerät nur in sehr gut belüfteten Räumen verwenden.

DMögliche Zündquellen, wie z.B. Dauerflammen, Zigaretten und statische Elektrizität von Plastik-Abdeckfolien, vermeiden. Im Spritzbereich kein Stromkabel ein- oder ausstecken und keinen Lichtschalter betätigen.

DSpritzgerät, Spritzobjekt sowie Material- und Lösemittelimer erden.

DBeim Spritzen in einen Eimer die Pistole fest an den geerdeten Eimer drücken.

DNur einen elektrisch leitfähigen Airless-Materialschlauch verwenden.

DNiemals 1,1,1-Trichlorethan, Methylenchlorid, andere Lösemittel mit halogenisierten Kohlenwasserstoffen oder Materialien, die solche Lösemittel enthalten, in druckbeaufschlagten Aluminiumgeräten verwenden. Dies könnte zu einer chemischen Reaktion führen und in der Folge eine Explosion verursachen.

Gevaar van materiaalinjectie en hoge druk: Spuitmateriaal onder hoge druk, ook uit lekken, kan binnendringen in het lichaam.

Om dit te voorkomen moet u altijd hierop letten:

DZet de veiligheidspal van de trekker in de geblokkeerde stand wanneer u niet spuit.

DBlijf uit de buurt van de spuitmond en van lekken.

DSpuit nooit zonder dat de tipbeschermer is geplaatst.

DVoer de **DRUKONTLASTPROCEDURE** uit wanneer u ophoudt met spuiten, of voordat u begint met onderhoudswerk.

DGebruik geen componenten die slecht geschikt zijn voor een lagere druk van de *maximum werkdruk*.

DSta nooit toe dat kinderen dit apparaat gebruiken.

DZorg dat u stevig staat; het pistool kan een terugslag geven wanneer de trekker wordt ingetrokken.

Als materiaal onder hoge druk door de huid is binnengedrongen kan de verwonding eruitzien als een "gewone snijwond". Maar het is een ernstige verwonding! Roep meteen medische hulp in.

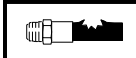

Gefahr durch Materialeinspritzung und Hochdruck: Durch Spritzer oder undichte Stellen kann Material mit hohem Druck in den Körper gespritzt werden.

Um Einspritzungen zu vermeiden, stets:

DDie Abzugssperre verriegeln, wenn nicht gespritzt wird.

DAbstand zur Düse und zu undichten Teilen halten!

DNiemals ohne Düsenschutz spritzen.

DDen **DRUCK ENTLASTEN**, wenn die Spritzarbeiten unterbrochen werden oder bevor Servicearbeiten am Spritzgerät durchgeführt werden.

DKeine Komponenten verwenden, die für einen geringeren Druck als den *zulässigen Betriebsüberdruck des Spritzgeräts ausgelegt sind*.

DNiemals Kinder an dieses Gerät lassen.

DDer Bediener muß beim Abziehen der Pistole auf einen guten Stand achten, da die Pistole beim Abziehen einen Rückstoß verursachen kann.

Wenn Material mit hohem Druck in die Haut eindringt, kann die dabei entstehende Wunde wie ein "einfacher Schnitt" aussehen. Tatsächlich ist es jedoch eine schwere Verletzung! In diesem Fall sofort einen Arzt aufsuchen.

CONTROLS / COMMANDES / BEDIENINGSORGANEN / REGLER

**Trigger Lock / Verrouillage gâchette
Trekkervergrendeling / Abzugssperre**



**Needle Adjustment
Réglage du pointeau
De naald afstellen
Nadeleinstellung**

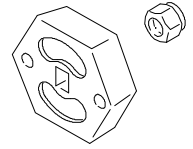

**Tip Guard / Garde-buse
Tipbeschermer
Abzugssperre**

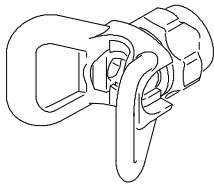

Tip / Buse / Tip / Düse

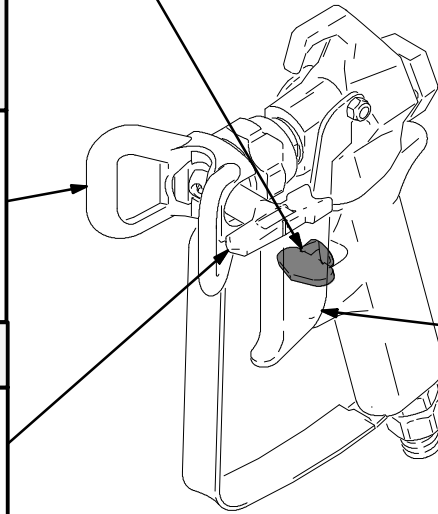
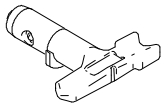

**Trigger / Gâchette
Trekker / Abzug**

**PRESSURE RELIEF / DÉCOMPRESSION
DRUKONTLASTING / DRUCKENTLASTUNG**



Follow 1-5 when you stop spraying.
Effectuer les opérations 1-5 lors d'un arrêt de la pulvérisation.
Voer de stappen 1-5 uit wanneer u stopt met spuiten.
Schritte 1-5 ausführen, wenn die Spritzarbeiten beendet werden.

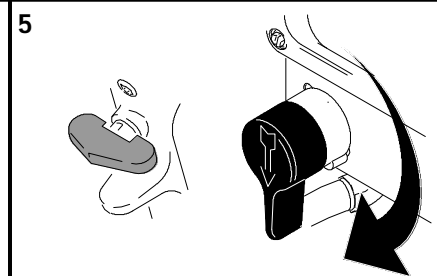
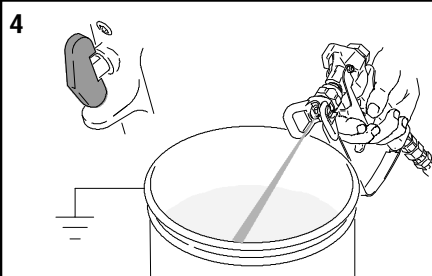
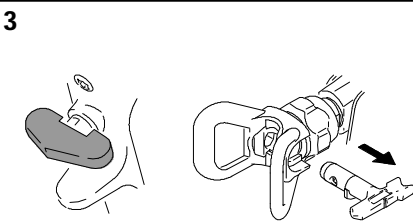
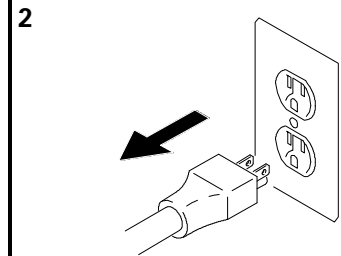
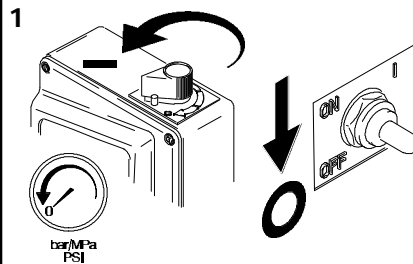

INSTALLATION / INSTALLATION / INSTALLATIE / INSTALLATION

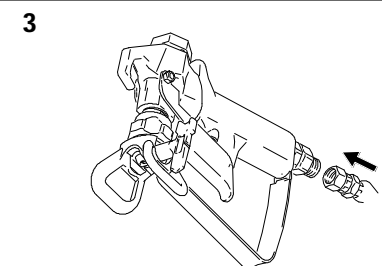
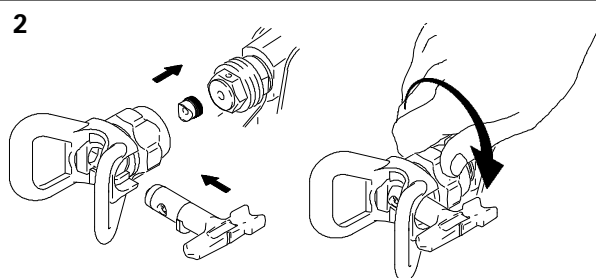
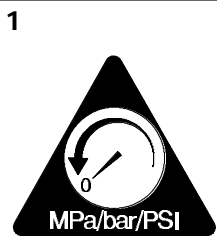

**ALIGN SPRAY / ALIGNER LE JET
SPUITPATROON UITLIJNEN / SPRITZBILD AUSRICHTEN**

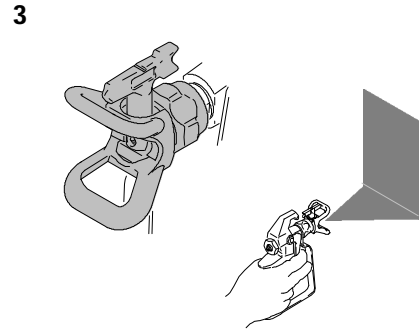
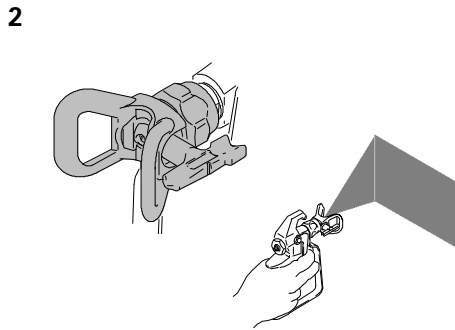
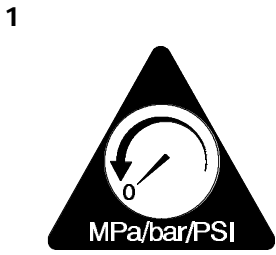

**ADJUST SPRAY / RÉGLER LE JET
AFSTELLEN SPUITPATROON / SPRITZBILD EINSTELLEN**

1

WARNING
WAARSCHUWING

MISE EN GARDE
WARNUNG

PRIME SPRAYER

AMORCER LE PULVÉRISATEUR

SPUITAPP. VULLEN

SPRITZGERÄT ENTLÜFTEN

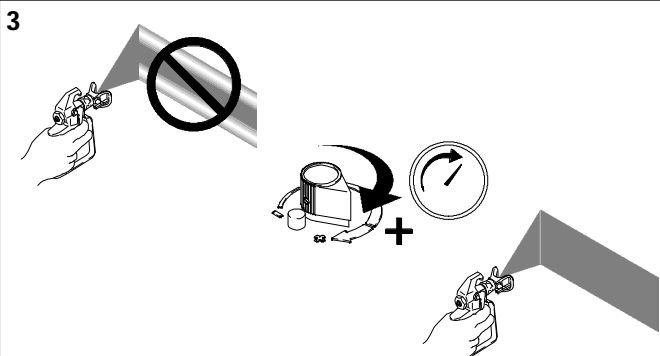

CLEAR CLOG / DÉBOUCHER LA BUSE / VERSTOPPING VERWIJDEREN / VERSTOPFUNG BESEITIGEN

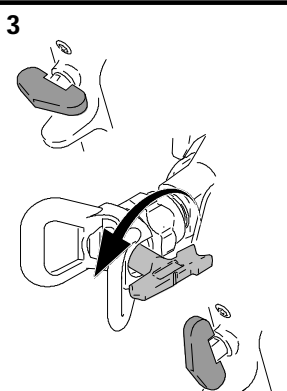
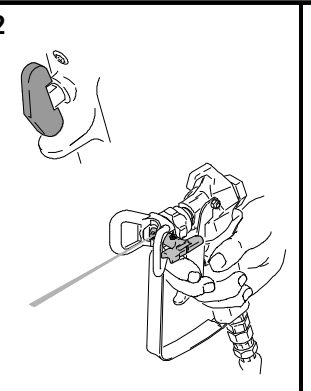
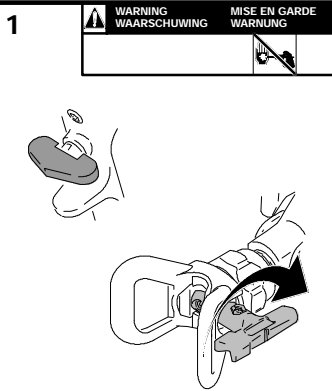

CAUTION
ATTENTION
VOORZICHTIG
VORSICHT



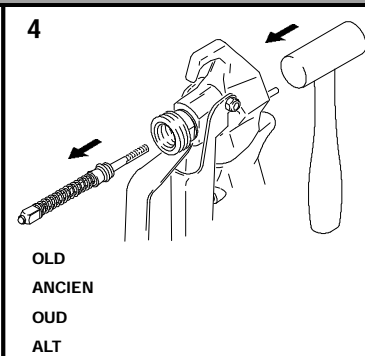
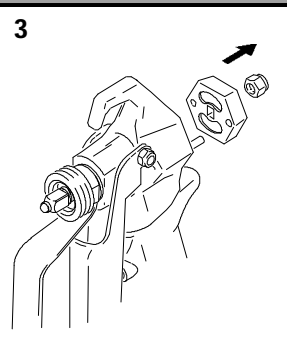
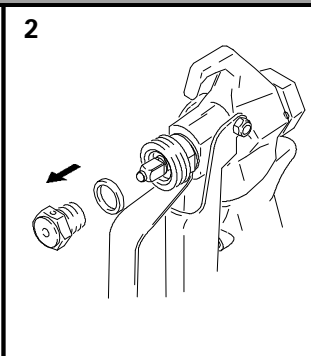
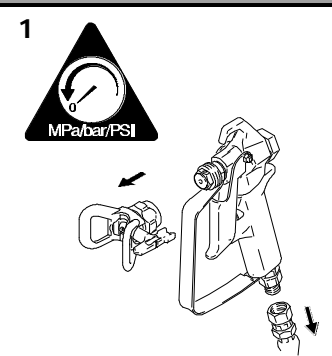

**REPLACE NEEDLE / REMPLACER LE POINTEAU
NAALD VERVERGEN / NADEL AUSWECHSELN**



**REPLACE NEEDLE / REMPLACER LE POINTEAU
NAALD VERVANGEN / NADEL AUSWECHSELN**

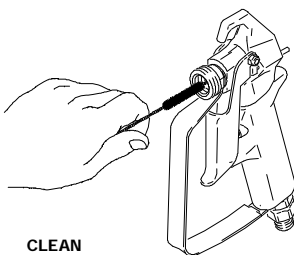
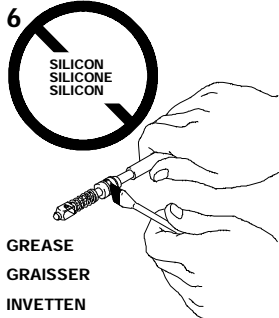
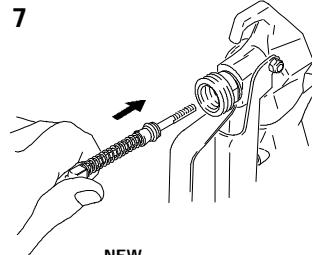
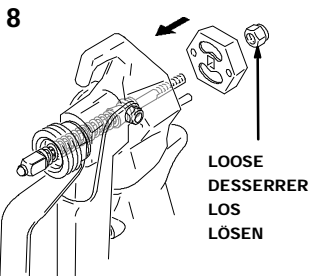
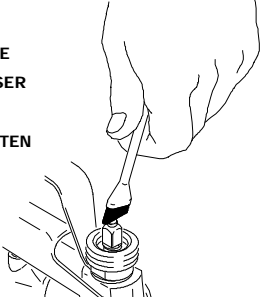

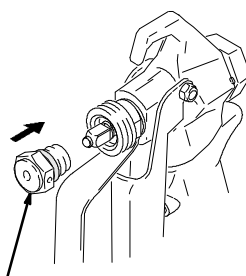

<p>5</p>  <p>CLEAN NETTOYER REINIGEN REINIGEN</p>	<p>6</p>  <p>SILICON SILICONE SILICON</p> <p>GREASE GRAISSER INVETTEN EINFETTEN</p>	<p>7</p>  <p>NEW NOUVEAU NIEUW NEU</p>	<p>8</p>  <p>LOOSE DESSERRER LOS LÖSEN</p>
<p>9</p>  <p>GREASE GRAISSER VET EINFETTEN</p>	<p>10</p>  <p>GREASE GRAISSER VET EINFETTEN</p>	<p>11</p>  <p>26-32 ft-lb / 26-32 pés-lb / 35-43 N.m</p>	

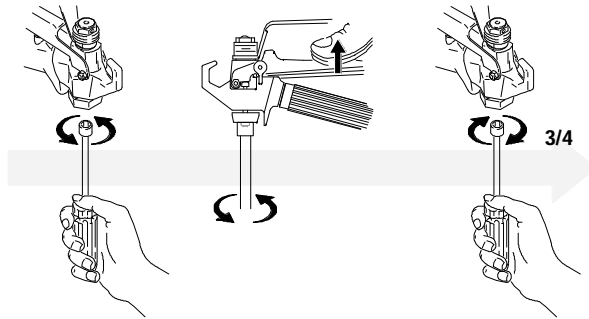
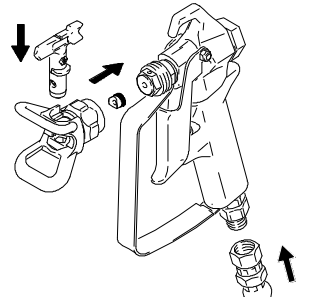

**ADJUST NEEDLE / RÉGLER LE POINTEAU
NAALD AFSTELLEN / NADEL EINSTELLEN**

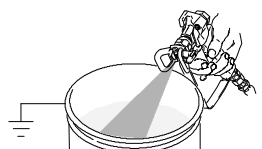
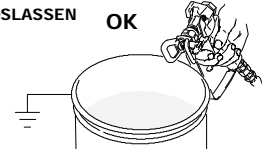
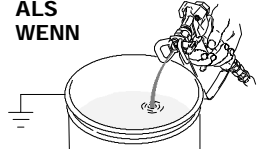
<p>1</p>  <p>3/4</p>	<p>2</p> 	<p>PRIME SPRAYER AMORCER LE PULVÉRISATEUR SPUITAPP. VULLEN SPRITZGERÄT ENTLÜFTEN</p>
--	--	---

✓ Trigger ✓ Gâchette ✓ Trekker ✓ Abzug

<p>5</p> <p>SQUEEZE APPUYER INKNIJPEN ZUSAMMEN- DRÜCKEN</p> 	<p>6</p> <p>RELEASE RELÂCHER LOSLATEN LOSLASSEN</p> <p>OK</p> 	<p>IF SI ALS WENN</p>  <p>THEN ALORS DAN DANN</p>  <p>MPa/bar/PSI</p> <p>ADJUST NEEDLE RÉGLER LE POINTEAU NAALD AFSTELLEN NADEL EINSTELLEN</p>
--	--	---

✓ Trigger Lock ✓ Verrouillage gâchette ✓ Trekkervergrendeling ✓ Abzugssperre

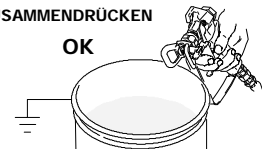
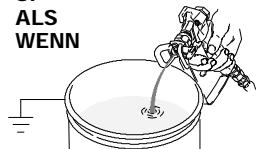
<p>7</p>  	<p>8</p> <p>SQUEEZE APPUYER INKNIJPEN ZUSAMMEN- DRÜCKEN</p> <p>OK</p> 	<p>IF SI ALS WENN</p>  <p>THEN ALORS DAN DANN</p>  <p>MPa/bar/PSI</p> <p>ADJUST NEEDLE RÉGLER LE POINTEAU NAALD AFSTELLEN NADEL EINSTELLEN</p>
---	--	---

Parts / Pièces / Onderdelen / Teile

Model 243282, Series A
Includes items 1 and 4 to 42

Model 235990, Series C
Includes items 1 to 39

Model 217593, Series E
Includes items 1 to 39

Model 824950, Series A
Includes items 1 and 4 to 42

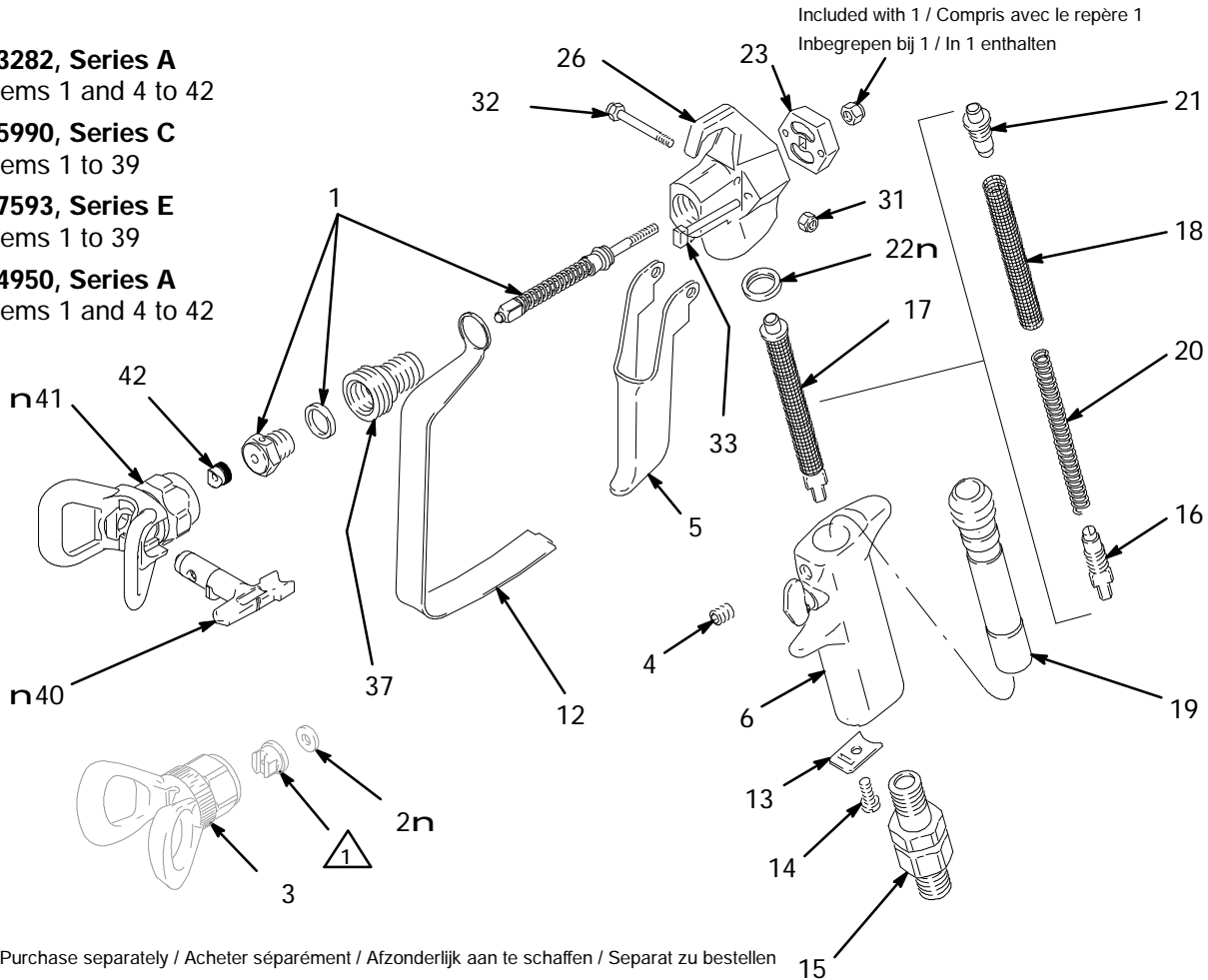

Purchase separately / Acheter séparément / Afzonderlijk aan te schaffen / Separat zu bestellen

9644A

Ref. No.	Part No.	Description	Qty.	Ref. No.	Part No.	Description	Qty.
1	218070	NEEDLE-DIFFUSER/SEAT KIT	1	20	179763	SPRING	1
2n	166969	GASKET, tip (used with flat tips only)	1	21	179722	SPRING RETAINER (color coded blue) (for standard 50 mesh; 300 micron filter)	1
3	220251	TIP GUARD	1	21a	179957	SPRING RETAINER (color coded orange) (for optional 100 mesh; 149 micron filter)	1
4	100421	SETSCREW, soc hd, 5/16-18 x 3/8"	1	22n	179733	GASKET	1
5	179734	2 FINGER TRIGGER (standard)	1	23	191244	END CAP	1
5a	179943	4 FINGER TRIGGER (Model 235990 only)	1	26	179718	FLUID HOUSING	1
6	218643	GUN HANDLE ASSEMBLY includes replaceable items 4, 13, 14	1	31	105334	LOCKNUT; M4 x 0,7 thread	1
10Y	172479	INSTRUCTION TAG	1	32	177538	TRIGGER STUD	1
11Y	179761	WARNING TAG	1	33	179737	ACTUATOR PIN	2
12	195495	TRIGGER GUARD	1	37	195419	NEEDLE HOUSING	1
13	179730	GUARD RETAINER	1	39Y	222385	WARNING CARD (not shown)	1
14	109575	SCREW, 8-32 x 5/16"	1	40n	286517	RAC 5 SWITCHTIP TIP, SZ 517	1
15	218021	SWIVEL	1	41n	243161	HANDTITE [†] TIP GUARD	1
16	179750	SPRING RETAINER	1	42	243281	OneSealt [†] (5 pack)	1
17n	218131	FLUID FILTER ASSEMBLY (standard 50 mesh; 300 micron) includes replaceable items 16, 18, 20, 21	1	Y Replacement Danger and Warning labels, tags and cards are available at no cost. / Les étiquettes et les panonceaux de danger et de mise en garde supplémentaires sont disponibles gratuitement. / Extra labels, plaatjes en kaarten, die waarschuwen voor gevaar, zijn gratis verkrijgbaar. / Zusätzliche Gefahren- und Warnschilder, Aufkleber und Karten sind kostenlos erhältlich.			
17a	218133	FLUID FILTER ASSEMBLY (optional 100 mesh; 149 micron) includes replaceable items 16, 18a, 20, 21a	1				
18	179731	STRAINER ELEMENT (standard 50 mesh; 300 micron)	1	n Keep these spare parts on hand to reduce down time. / Garder ces pièces de rechange à portée de la main pour réduire les temps morts. / Houd deze onderdelen bij de hand, voor minder tijdverlies bij onderhoud. / Diese Teile auf Lager halten, um Standzeiten zu verkürzen.			
18a	179732	STRAINER ELEMENT (optional 100 mesh; 149 micron)	1				
19	179721	FLUID TUBE	1				
6	3W9091						

Graco Standard Warranty

Garantie Graco standard

Graco Standaardgarantie

Graco Standardgarantie

Graco warrants all equipment referenced in this document which is manufactured by Graco and bearing its name to be free from defects in material and workmanship on the date of sale by an authorized Graco distributor to the original purchaser for use. With the exception of any special, extended, or limited warranty published by Graco, Graco will, for a period of twelve months from the date of sale, repair or replace any part of the equipment determined by Graco to be defective. This warranty applies only when the equipment is installed, operated and maintained in accordance with Graco's written recommendations.

This warranty does not cover, and Graco shall not be liable for general wear and tear, or any malfunction, damage or wear caused by faulty installation, misapplication, abrasion, corrosion, inadequate or improper maintenance, negligence, accident, tampering, or substitution of non-Graco component parts. Nor shall Graco be liable for malfunction, damage or wear caused by the incompatibility of Graco equipment with structures, accessories, equipment or materials not supplied by Graco, or the improper design, manufacture, installation, operation or maintenance of structures, accessories, equipment or materials not supplied by Graco.

This warranty is conditioned upon the prepaid return of the equipment claimed to be defective to an authorized Graco distributor for verification of the claimed defect. If the claimed defect is verified, Graco will repair or replace free of charge any defective parts. The equipment will be returned to the original purchaser transportation prepaid. If inspection of the equipment does not disclose any defect in material or workmanship, repairs will be made at a reasonable charge, which charges may include the costs of parts, labor, and transportation.

THIS WARRANTY IS EXCLUSIVE, AND IS IN LIEU OF ANY OTHER WARRANTIES, EXPRESS OR IMPLIED, INCLUDING BUT NOT LIMITED TO WARRANTY OF MERCHANTABILITY OR WARRANTY OF FITNESS FOR A PARTICULAR PURPOSE.

Graco's sole obligation and buyer's sole remedy for any breach of warranty shall be as set forth above. The buyer agrees that no other remedy (including, but not limited to, incidental or consequential damages for lost profits, lost sales, injury to person or property, or any other incidental or consequential loss) shall be available. Any action for breach of warranty must be brought within two (2) years of the date of sale.

GRACO MAKES NO WARRANTY, AND DISCLAIMS ALL IMPLIED WARRANTIES OF MERCHANTABILITY AND FITNESS FOR A PARTICULAR PURPOSE, IN CONNECTION WITH ACCESSORIES, EQUIPMENT, MATERIALS OR COMPONENTS SOLD BUT NOT MANUFACTURED BY GRACO. These items sold, but not manufactured by Graco (such as electric motors, switches, hose, etc.), are subject to the warranty, if any, of their manufacturer. Graco will provide purchaser with reasonable assistance in making any claim for breach of these warranties.

In no event will Graco be liable for indirect, incidental, special or consequential damages resulting from Graco supplying equipment hereunder, or the furnishing, performance, or use of any products or other goods sold hereto, whether due to a breach of contract, breach of warranty, the negligence of Graco, or otherwise.

FOR GRACO BRAZILIAN/CANADIAN/COLUMBIAN CUSTOMERS

The Parties acknowledge that they have required that the present document, as well as all documents, notices and legal proceedings entered into, given or instituted pursuant hereto or relating directly or indirectly hereto, be drawn up in English.

À L'ATTENTION DES CLIENTS BRÉSILIENS/CANADIENS/COLOMBIENS DE GRACO

Les parties reconnaissent avoir convenu que la rédaction du présente document sera en Anglais, ainsi que tous documents, avis et procédures judiciaires exécutés, donnés ou intentés à la suite de ou en rapport, directement ou indirectement, avec les procédures concernées.

FOR GRACO BRAZILIAN/CANADIAN/COLUMBIAN CUSTOMERS

The Parties acknowledge that they have required that the present document, as well as all documents, notices and legal proceedings entered into, given or instituted pursuant hereto or relating directly or indirectly hereto, be drawn up in English.

FÜR GRACO-KUNDEN IN BRASILIEN/KANADA/KOLUMBIEN

Die Parteien bestätigen, daß sie festgelegt haben, daß das vorliegende Dokument sowie alle anderen Dokumente, Mitteilungen und Gerichtsverfahren, die im Zusammenhang damit erstellt, verteilt oder eingeleitet werden, oder sich direkt oder indirekt darauf beziehen, in englischer Sprache sein sollen.

ADDITIONAL WARRANTY COVERAGE / AVENANT DE GARANTIE AANVULLENDE GARANTIEDEKING / ZUSÄTZLICHER GARANTIEUMFANG

Graco does provide extended warranty and wear warranty for products described in the "Graco Contractor Equipment Warranty Program".

Graco accorde une garantie étendue et se porte garant des produits décrits dans le "Programme de garantie d'équipements des fournisseurs Graco".

Graco verleent wel aanvullende garantie en garantie tegen slijtage voor producten die beschreven zijn in het "Graco Contractor Equipment Warranty Program" (een garantieprogramma voor aannemers).

Graco gewährt eine erweiterte Garantie und eine Verschleißgarantie für die im "Garantieprogramm für Graco-Contractorgeräte" beschriebenen Produkte.

Technical Data / Caractéristiques techniques Onderdelen / Teile

Category	Data
Maximum fluid working pressure	3600 psi (248 bar, 24,8 MPa)
Fluid orifice size	0,125 in. (3,18 mm)
Wetted parts	Stainless steel, Polyethylene, Polyurethane, Nylon, PTFE
Weight	18 oz (510 g)
Inlet	1/4 npsm(m) swivel
Maximum material temperature	120_F (50_C)
* Sound pressure level	78 dBa
* Sound power level	87 dBa

- * Measured while spraying waterbase paint - gravity 1,36 through a 517 tip at 3000 psi (207 bar) per ISO 3744.
- * Mesuré lors d'une pulvérisation de peinture à l'eau - poids spécifique de 1,36 avec une buse de 517 à 3000 psi (207 bar, 20,7 MPa) selon la norme ISO 3744.
- * Gemeten tijdens spuiten met verf op waterbasis met een soortelijk gewicht van 1,36 door een 517 tip bij 3000 psi (207 bar, 20,7 MPa) conform ISO 3744.
- * Gemessen beim Spritzen von Lack auf Wasserbasis - Gravität 1,36 durch eine 517er-Düse bei 3000 psi (207 bar, 20,7 MPa) nach ISO 3744.

TO PLACE AN ORDER OR FOR SERVICE, contact your Graco distributor,
or call 1-800-690-2894 to identify the nearest distributor.

POUR PASSER COMMANDE OU DEMANDER UNE PRESTATION D'ENTRETIEN, contactez votre distributeur Graco
Neem contact op met uw Graco-dealer **OM TE BESTELLEN EN VOOR SERVICE**,
of bel 1-800-690-2894 voor de gegevens van de dichtstbijzijnde dealer.

FÜR EINE BESTELLUNG ODER EINE SERVICE-ANFORDERUNG nehmen Sie bitte mit Ihrem Graco-Händler Kontakt
auf, oder rufen Sie 1-800-690-2894, um die Adresse des nächstgelegenen Händlers zu erfahren.

All written and visual data contained in this document reflects the latest product information available at the time of publication. Graco reserves the right to make changes at any time without notice.

Toutes les données écrites et visuelles figurant dans ce document reflètent les toutes dernières informations disponibles au moment de sa publication. Graco se réserve le droit de procéder à des modifications à tout moment sans avis préalable.

Alle geschreven en afgebeelde gegevens in dit document zijn een weergave van de meest recente productinformatie die beschikbaar was op het moment van publicatie. Graco behoudt zich het recht voor om te allen tijde wijzigingen aan te brengen zonder mededeling vooraf. Die in dieser Dokumentation enthaltenen Daten entsprechen dem Stand zum Zeitpunkt der Drucklegung. Änderungen vorbehalten.

Sales Offices: Minneapolis, Detroit
Foreign Offices: Belgium, Korea, Hong Kong, Japan
Bureaux des ventes: Minneapolis, Detroit
Bureaux à l'étranger: Belgique, Corée, Hong-Kong, Japon
Verkoopkantoren: Minneapolis, Detroit
Buitenlandse kantoren: België, Korea, Hong Kong, Japan
Verkaufsstellen: Minneapolis, Detroit
Auslandszweigstellen: Belgien; Korea, Hong Kong, Japan

**GRACO N.V.; Industrieterrein — Oude Bunders;
Slakweidestraat 31, 3630 Maasmechelen, Belgium
Tel.: 32 89 770 700 - Fax: 32 89 770 777**

<http://www.graco.com>

PRINTED IN USA 3W9091 11/1999
 IMPRIMÉ AUX É.-U. 3W9091 11/1999
 GEDRUKT IN DE VS 3W9091 11/1999
 PRINTED IN USA 3W9091 11/1999