



# Models

Model	Series	Description
233718	A	Lo-Boy
233719	A	Hi-Boy
233720	A	Lo-Boy with RAC <sup>®</sup> X tip, gun and hose
233721	A	Hi-Boy with RAC X tip, gun and hose

## Table of Contents

Warnings and Cautions .....	3	Parts	
Maintenance .....	4	Pinion Assembly .....	17
Troubleshooting .....	5	Sprayers .....	18
Repair		Pressure Control .....	21
Rollers .....	8	Tip, Gun, Hose .....	22
Drive Housing .....	9	Dimensions .....	23
Cam Follower Bearings .....	10	Technical Data .....	23
Engine .....	11	Graco Warranty .....	24
Pressure Control .....	13	Graco Phone Number .....	24
Displacement Pump .....	15		

# Warnings and Cautions

## Warning Symbol









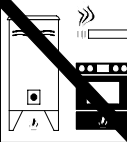

This symbol alerts you to the possibility of serious injury or death if you do not follow the instructions.

## Caution Symbol

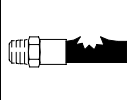

This symbol alerts you to the possibility of damage to or destruction of equipment if you do not follow the instructions.

 <b>WARNING</b>	
<p><b>Fire and explosion:</b> Solvent and paint fumes can ignite or explode.</p> <p><b>To help prevent a fire and explosion:</b></p> <ul style="list-style-type: none"> <li>● <b>Use only in an extremely well ventilated area.</b></li> <li>● Eliminate all ignition sources; such as pilot lights, cigarettes and plastic drop cloths (static arc hazard). Do not plug or unplug power cords or turn lights on or off in spray area.</li> <li>● Ground Sprayer, object being sprayed, paint and solvent pails.</li> <li>● Hold gun firmly to side of grounded pail when triggering into pail.</li> <li>● Use only conductive airless paint hose.</li> <li>● Do not use 1,1,1-trichloroethane, methylene chloride, other halogenated hydrocarbon solvents or fluids containing such solvents in pressurized aluminum equipment. Such use could result in a chemical reaction, with the possibility of explosion.</li> <li>● Do not fill fuel tank while engine is running or hot.</li> <li>● Do not flush with gasoline.</li> </ul>	
<p><b>Fluid injection and high pressure hazard:</b> High pressure spray or leaks can inject fluid into the body.</p> <p><b>To help prevent injection, always:</b></p> <ul style="list-style-type: none"> <li>● Engage trigger safety latch when not spraying.</li> <li>● Keep clear of nozzle and leaks.</li> <li>● Never spray without a tip guard.</li> <li>● Do <b>PRESSURE RELIEF</b> if you stop spraying or begin servicing sprayer.</li> <li>● Do not use components rated less than sprayer <i>Maximum Working Pressure</i>.</li> <li>● Never allow children to use this unit.</li> </ul> <p><b>If high pressure fluid pierces your skin,</b> the injury might look like "just a cut", but it is a serious wound! Get immediate medical attention.</p>	
	
	
	
	
	

# Maintenance

## WARNING



### INJECTION HAZARD

The system pressure must be manually relieved to prevent the system from starting or spraying accidentally. Fluid under high pressure can be injected through the skin and cause serious injury. To reduce the risk of an injury from injection, splashing fluid, or moving parts, follow the **Pressure Relief Procedure** whenever you:

- are instructed to relieve the pressure,
- stop spraying,
- check or service any of the system equipment,
- or install or clean the spray tip.

## Pressure Relief Procedure

1. Lock gun trigger safety.
2. Turn engine ON/OFF switch to OFF.
3. Move pressure control switch to OFF and turn pressure control knob fully counterclockwise.
4. Unlock trigger safety. Hold metal part of gun firmly to side of grounded metal pail, and trigger gun to relieve pressure.
5. Lock gun trigger safety.
6. Open pressure drain valve. Leave valve open until ready to spray again.

*If you suspect that the spray tip or hose is completely clogged, or that pressure has not been fully relieved after following the steps above, VERY SLOWLY loosen tip guard retaining nut or hose end coupling to relieve pressure gradually, then loosen completely. Now clear tip or hose.*

## CAUTION

For detailed engine maintenance and specifications, refer to separate Honda Engines Owner's Manual, supplied.

**DAILY:** Check engine oil level and fill as necessary.

**DAILY:** Check hose for wear and damage.

**DAILY:** Check gun safety for proper operation.

**DAILY:** Check pressure drain valve for proper operation.

**DAILY:** Check and fill the gas tank.

### **AFTER THE FIRST 20 HOURS OF OPERATION:**

Drain engine oil and refill with clean oil. Reference Honda Engines Owner's Manual for correct oil viscosity.

**WEEKLY:** Remove air filter cover and clean element. Replace element, if necessary. If operating in an unusually dusty environment: check filter daily and replace, if necessary.

Replacement elements can be purchased from your local HONDA dealer.

**WEEKLY:** Check level of TSL in displacement pump packing nut. Fill nut, if necessary. Keep TSL in nut to help prevent fluid buildup on piston rod and premature wear of packings.

### **AFTER EACH 100 HOURS OF OPERATION:**

Change engine oil. Reference Honda Engines Owner's Manual for correct oil viscosity.

**SPARK PLUG:** Use only BPR6ES (NGK) or W20EPR-U (NIPPONDENSO) plug. Gap plug to 0.028 to 0.031 in. (0.7 to 0.8 mm). Use spark plug wrench when installing and removing plug.

# Troubleshooting



Relieve pressure; page 4.

PROBLEM	CAUSE	SOLUTION
E=XX is displayed	Fault condition exists	Determine fault correction from table, page 14.
Engine won't start	Engine switch is OFF	Turn engine switch ON
	Engine is out of gas	Refill gas tank. Honda Engines Owner's Manual.
	Engine oil level is low	Try to start engine. Replenish oil, if necessary. Honda Engines Owner's Manual.
	Spark plug cable is disconnected or damaged	Connect spark plug cable or replace spark plug
	Cold engine	Use choke
	Fuel shutoff lever is OFF	Move lever to ON position
	Oil is seeping into combustion chamber	Remove spark plug. Pull starter 3 to 4 times. Clean or replace spark plug. Start engine. Keep sprayer upright to avoid oil seepage.
False tripping of WatchDog system. <b>EMPTY</b> is displayed. Pump does not run.	Operating conditions out of WatchDog parameters	Turn pressure down. Contact Graco Technical Assistance to adjust WatchDog parameters. Operate without WatchDog active; Manual 309408.
	Low pump output.	See Troubleshooting Table, Pump Outlet Low, page 6.
Engine operates, but displacement pump does not operate	Error code displayed?	Determine fault correction from table, page 14.
	Pump switch is OFF	Turn pump switch ON.
	Pressure setting is too low	Turn pressure adjusting knob clockwise to increase pressure.
	Fluid filter (318) is dirty	Clean filter. Page 20.
	Tip or tip filter is clogged	Clean tip or tip filter. Manual 309091.
	Displacement pump piston rod is stuck due to dried paint	Repair pump. Manual 309277.
	Connecting rod is worn or damaged	Replace connecting rod. Page 15.
	Drive housing is worn or damaged	Replace drive housing. Page 9.
	Electrical power is not energizing clutch field	Check wiring connections. Page 11. Reference pressure control repair. Page 13. Reference wiring diagram. Page 21.  With pump switch ON and pressure turned to MAXIMUM, use a test light to check for power between clutch test points on control board.  Remove 7-pin connector from control board and measure resistance across clutch coil. At 70° F, the resistance must be between 1.7 ±0.2Ω ; if not, replace pinion housing.  Have pressure control checked by authorized Graco dealer.

# Troubleshooting

PROBLEM	CAUSE	SOLUTION
	Clutch is worn, damaged, or incorrectly positioned	Replace clutch. Manual 309890.
	Pinion assembly is worn or damaged	Repair or replace pinion assembly. Manual 309890.
Pump output is low.	Strainer (89) is clogged	Clean strainer. Sprayer 233716 strainer is for use in paint only.
	Piston ball (206) is not seating	Service piston ball. Manual 309277.
	Piston packings are worn or damaged	Replace packings. Manual 309277.
	O-ring (227) in displacement pump is worn or damaged	Replace o-ring. Manual 309277.
	Intake valve ball is not seating properly	Clean intake valve. Manual 309277.
	Intake valve ball is packed with material	Clean intake valve. Manual 309277. Do not leave 233716 sprayer under pressure for more than 5 minutes when spraying texture and not actively spraying.
	Engine speed is too low	Increase throttle setting. Manual 309408.
	Clutch is worn or damaged	Replace clutch. Manual 309890.
	Pressure setting is too low	Increase pressure. Manual 309408.
	Fluid filter (318), tip filter or tip is clogged or dirty	Clean filter. Manual 309408 or 309091.
	Large pressure drop in hose with heavy materials	Use larger diameter hose and/or reduce overall length of hose. Use of more than 100 ft of 1/4 in. hose significantly reduces performance of sprayer. Use 3/8 in. hose for optimum performance (50 ft minimum).
Excessive paint leakage into throat packing nut	Throat packing nut is loose	Remove throat packing nut spacer. Tighten throat packing nut just enough to stop leakage.
	Throat packings are worn or damaged	Replace packings. Manual 309277.
	Displacement rod is worn or damaged	Replace rod. Manual 309277.
Fluid is spitting from gun	Air in pump or hose	Check and tighten all fluid connections. Re-prime pump. Manual 309408.
	Tip is partially clogged	Clear tip. Manual 309091.
	Fluid supply is low or empty	Refill fluid supply. Prime pump. Manual 309408. Check fluid supply often to prevent running pump dry.
Pump is difficult to prime	Air in pump or hose	Check and tighten all fluid connections. Reduce engine speed and cycle pump as slowly as possible during priming.
	Intake valve is leaking	Clean intake valve. Be sure ball seat is not nicked or worn and that ball seats well. Reassemble valve.
	Pump packings are worn	Replace pump packings. Manual 309277.
	Paint is too thick	Thin the paint according to the supplier's recommendations

# Troubleshooting

PROBLEM	CAUSE	SOLUTION
	Engine speed is too high	Decrease throttle setting before priming pump. Manual 309408.
Clutch squeaks each time clutch engages	Clutch surfaces are not matched to each other when new and may cause noise	Clutch surfaces need to wear into each other. Noise will dissipate after a day of run time.
High engine speed at no load	Misadjusted throttle setting	Reset throttle to 3700 engine rpm at no load
	Worn engine governor	Replace or service engine governor
Gallon counter not working	Bad sensor, broken or disconnected wire	Check connections. Replace sensor or wire.
No display, sprayer operates	Display damaged or has bad connection	Check connections. Replace display.
Clutch squeaks each time clutch engages	Clutch surfaces are not matched to each other when new and may cause noise	Clutch surfaces need to wear into each other. Noise will dissipate after a day of run time
Engine stalls	Engine speed is too slow	<ul style="list-style-type: none"> <li>• Increase throttle setting</li> <li>• Adjust engine speed at no load to 3750 - 3850 rpm</li> </ul>
	Fluid filter is clogged	Relieve pressure and clean filter
	Too much pump friction (new pump)	Reduce pressure to 3000 psi until pump wears in
	Spark plug wire is loose	Reconnect wire

# Rollers

## Removal

1.  Relieve pressure; page 4.
2. Fig. 1. Remove six cap screws (56) lock washers (87), clip (35), and cover assembly (13).

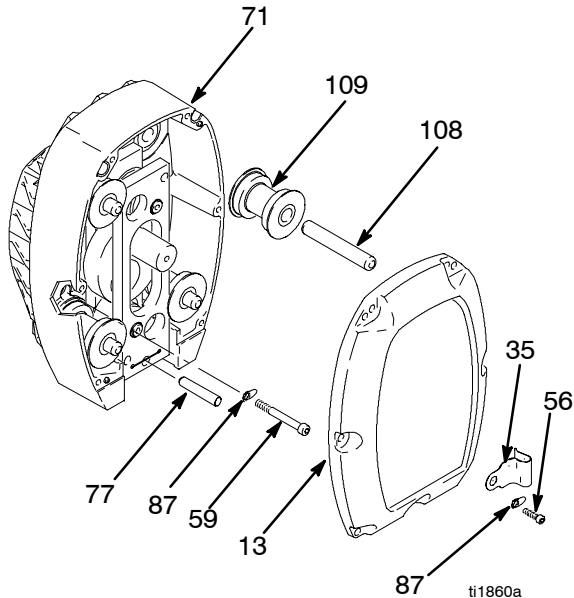

Fig. 1

Note: A screw driver may be needed to pry off cover assembly.

3. Remove dowel pins (108) and rollers (109)

## Installation

1. Install rollers (109) and dowel pins (108)
2. Install cover assembly (13) with six lock washers (87), clip (35), and cap screws (56).



# Drive Housing

## Removal

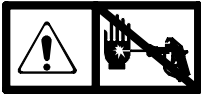
1.  Relieve pressure; page 4.
2. Fig. 2. Disconnect gallon counting sensor.

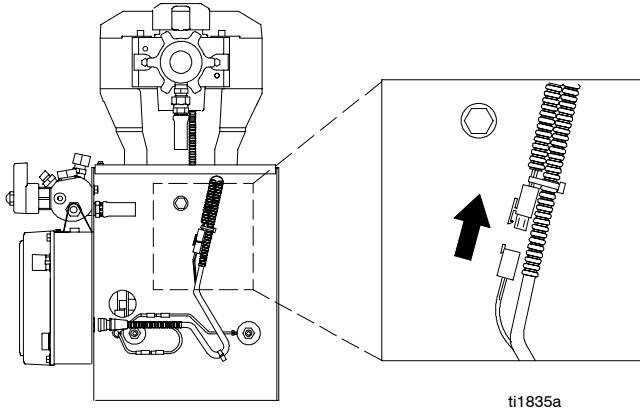

**Fig. 2**

3. Fig. 1. Remove six cap screws (56) lock washers (87) and cover assembly (13).
4. Fig. 3. Remove two screws (59) and washers (87).
5. Remove four cap screws (56) lock washers (87) from drive housing (71).
6. Lightly tap around drive housing (71) to loosen drive housing. Pull drive housing straight off pinion housing. Be prepared to support gear cluster (102), which may also come out.

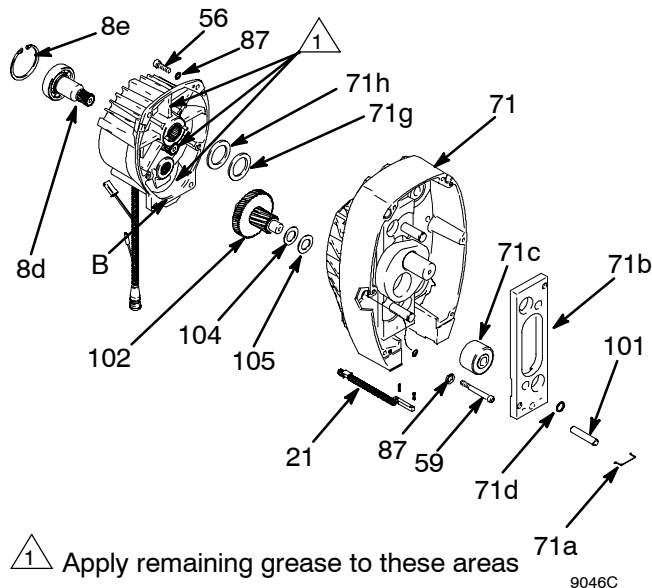

**Fig. 3**

## Installation

1. Liberally apply bearing grease (supplied with replacement gear cluster) to gear cluster (102), washers (104) and (105) and to areas called out by note 1. Use full 0.68 pint (0.32 liter) of grease for GMax 7900.
2. Place bronze colored washer (105) and silver colored washer (104) onto drive housing (71). Install gear cluster (102) through washers (105) and (104).
3. Place bronze colored washer (71g) and silver colored washer (71h) on shaft protruding from large shaft of drive housing (71). Align gears and push new drive housing straight onto pinion housing and locating pins (B).
4. Install two washers (87) and screws (59).
5. Install four lock washers (87) and cap screws (56) into drive housing (71).
6. Install cover assembly (13) with six lock washers (87) and cap screws (56).
7. Fig. 4. Reconnect gallon counting sensor.

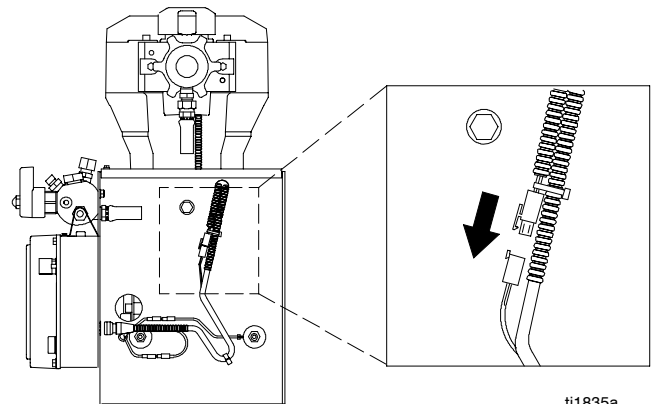

**Fig. 4**

# Cam Follower Bearings

## Removal

1.  Relieve pressure; page 4.
2. Fig. 9. Cycle pump piston rod (222) to lowest position. Turn engine off.
3. Fig. 5. Remove six cap screws (56), lock washers (87) and cover assembly (13).

Note: A screw driver may be needed to pry off cover assembly.

4. Remove four dowel pins (108) and rollers (109).
5. From front, drive out pump pin (77) with a screw driver.
6. Remove two retainer rings (71d).
7. Remove cam follower plate (71b).

Note: Two 1/2 in. x 13 bolts may be needed to remove cam follower plates.

8. Remove two cam follower bearings (71c).

## Installation

1. Install two cam follower bearings (71c).
2. Install cam follower plate (71b).
3. Install two retainer rings (71d).
4. Drive in pump pin (77) until it engages with pump pin retaining clip (71a).
5. Install four rollers (109) and dowel pins (108).
6. Install cover assembly (13) with six lock washers (87) and cap screws (56).

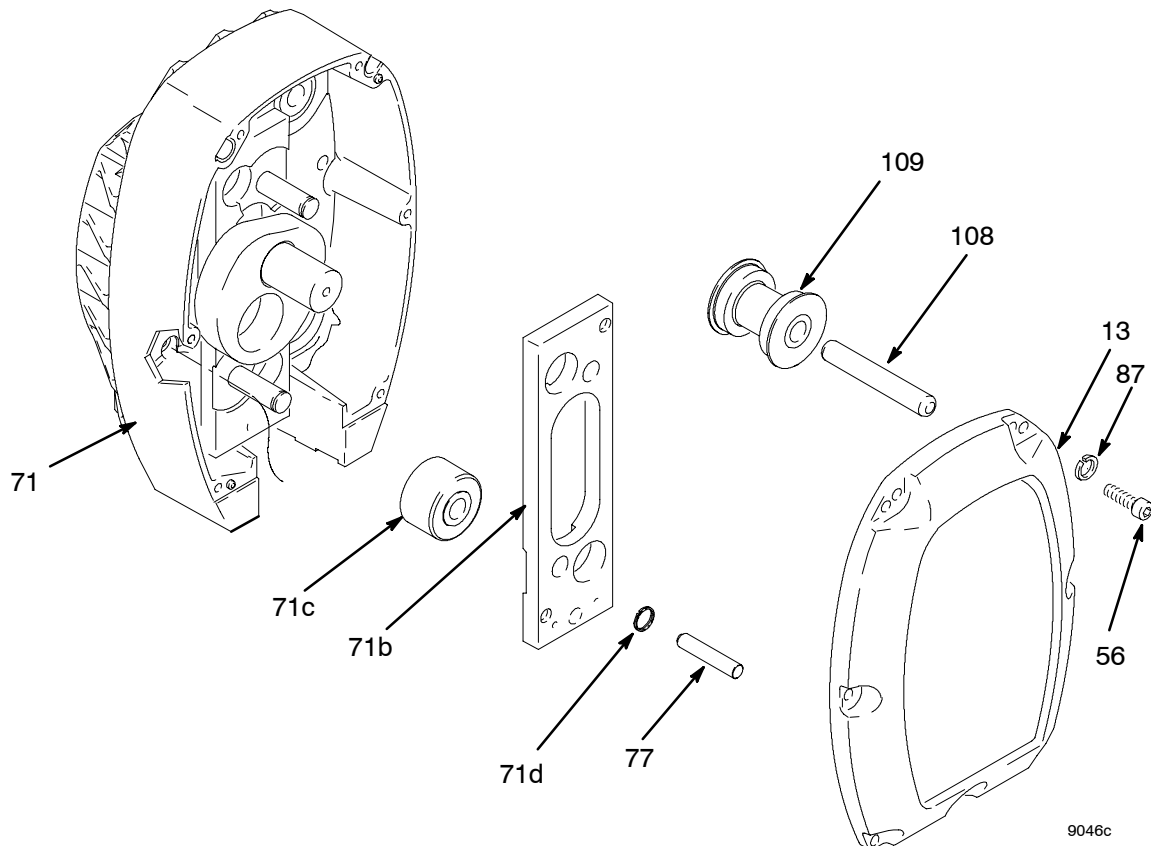

Fig. 5

9046c

# Engine

## Removal

1. Remove **Pinion Assembly/Rotor/Field/Pinion/Clutch, Clamp** and **Clutch Housing**, as instructed in manual 309890.
2. Fig. 6. Disconnect all necessary wiring.
3. Fig. 7. Remove two locknuts (7) and screws (6) from base of engine.
4. Lift engine carefully and place on work bench.

**NOTE:** All service to the engine must be performed by an authorized HONDA dealer.

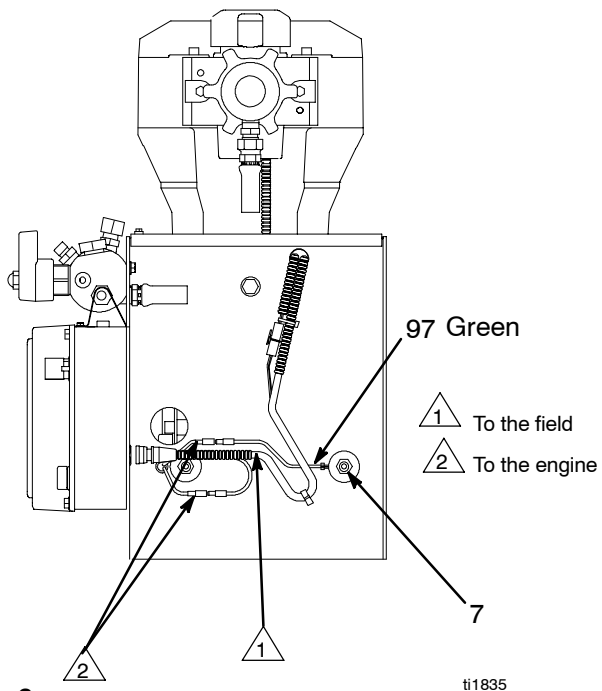

Fig. 6

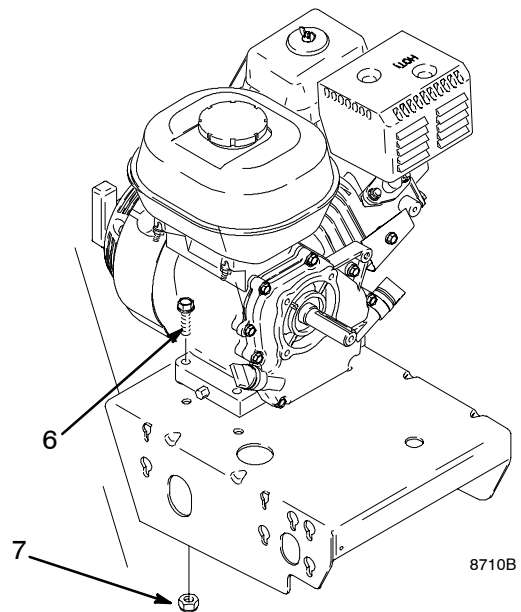



Fig. 7

## Installation

1. Lift engine carefully and place on cart.
2. Fig. 7. Install two screws (6) in base of engine and secure with locknuts (7). Torque to 200 in-lb (22.6 N•m).
3. Fig. 6. Connect all necessary wiring.
4. Install **Pinion Assembly/Rotor/Field/Pinion/Clutch, Clamp** and **Clutch Housing**, as instructed in manual 309890.

# On/Off Switch

## Removal

-  1. Relieve pressure; page 4.
2. Fig. 8. Remove four screws (54) and display/cover (52).
3. Pull display connector wings (A) open on PC board and pull display connector out.
4. Disconnect ON/OFF switch connector (B) from PC board.
5. Press in on two retaining tabs on each side of ON/OFF switch (51) and remove switch.

## Installation

1. Install new ON/OFF switch (51) so tabs of switch snap into place on inside of pressure control housing.
2. Connect ON/OFF switch connector (B) to PC board.
3. Push display connector into PC board close display connector wings (A) on PC board.
4. Install display/cover (52) with four screws (54).

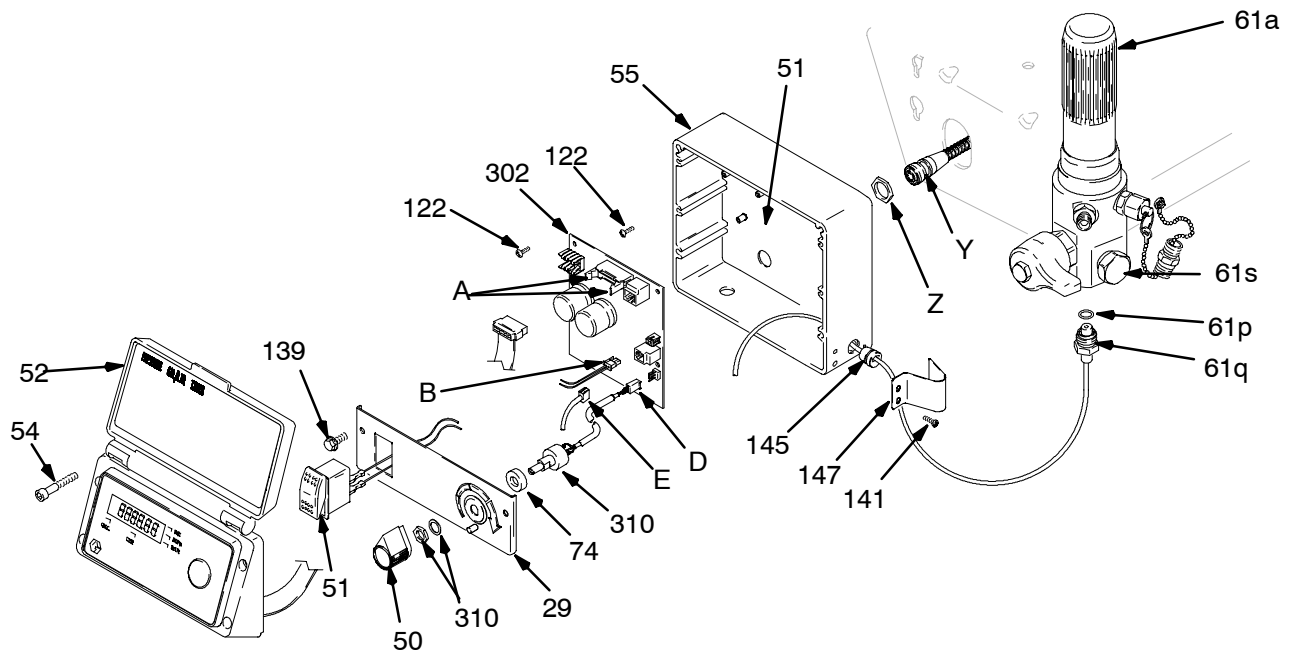



Fig. 8

ti1841a

# Pressure Control

## Control Board

### Removal

-  1. Relieve pressure; page 4.
2. Fig.8. Remove four screws (54) and display/cover (52). Pull display connector wings (A) open on PC board and pull display connector out.
3. Remove 2 screws (139).
4. Fig. 15. Disconnect at control board (302):
  - Lead (D) from potentiometer.
  - Lead (E) from transducer.
  - Lead (B) from On/Off Switch connector.
5. Fig. 8. Remove five screws (122) from control board and ground wire screw (122).
6. Remove connector (Y) at backside of pressure control. Remove jam nut (Z) and control board (302).

### Installation

When installing replacement control board, follow instructions with control board to set model type.

1. Fig. 8. Install control board (302) and jam nut (Z). Install connector (Y) at backside of pressure control.
2. Install ground wire and control board (302) with six screws (122).
3. Fig. 15. Connect to control board (302):
  - Connect ON/OFF switch connector (B).
  - Lead (E) to transducer.
  - Lead (D) to potentiometer.
4. Fig. 8. Push display connector into PC board close display connector wings (A) on PC board. Install display/cover (52) with four screws (54).

## Pressure Control Transducer

### Removal

-  1. Relieve pressure; page 4.
2. Fig. 8. Remove four screws (54) and cover (52).
3. Disconnect lead (E) from control board (302).
4. Remove two screws (141) and guard (147). Carefully pull transducer connector through rubber grommet (145).

5. Remove pressure control transducer (61q) and packing o-ring (61p) from filter housing (61e).

### Installation

1. Fig. 8. Install packing o-ring (61p) and pressure control transducer (61q) in filter housing (61e). Torque to 30–35 ft-lb.
2. Carefully feed transducer connector through rubber grommet (145). Install guard (147) with two screws (141).
3. Connect lead (E) to motor control board (302).
4. Install cover (52) with four screws (54).

## Pressure Adjust Potentiometer

### Removal

-  1. Relieve pressure; page 4.
2. Fig. 8. Remove four screws (54) and cover (52) and two screws (139).
3. Disconnect lead (D) from control board (302).
4. Loosen set screws on potentiometer knob (50) and remove knob, shaft nut, lockwasher (310) and pressure adjust potentiometer (310).
5. Remove spacer (74) from potentiometer (310).

### Installation

1. Install spacer (74) on potentiometer (310).
2. Fig. 8. Install pressure adjust potentiometer (310), shaft nut, lockwasher (310) and potentiometer knob (50).
  - a. Turn potentiometer shaft (310) clockwise to internal stop. Assemble potentiometer knob (50) to strike pin on plate (29).
  - b. After adjustment of step a., tighten both set screws in knob 1/4 to 3/8 turn after contact with shaft.
3. Connect lead (D) to control board (302).
4. Install plate (29) with two screws (139).
5. Install cover (52) with four screws (54).

# Pressure Control Repair

## Digital Display Messages



Relieve pressure before repair; page 4. No display does not mean that sprayer is not pressurized.

DISPLAY	SPRAYER OPERATION	INDICATION	ACTION
No Display	Sprayer may be pressurized.	Loss of power or display not connected	Check power source. Relieve pressure before repair or disassembly. Verify display is connected.
- - - -	Sprayer may be pressurized.	Pressure less than 200 psi (14 bar, 1.4 MPa)	Increase pressure as needed
3000 psi 210 bar 21 MPa	Sprayer is pressurized. Power is applied. (Pressure varies with tip size and pressure control setting.)	Normal operation	Spray
E=02	Sprayer stops. Engine is running.	Exceeded pressure limit	Remove any filter clogs or flow obstructions. Make sure gun trigger is locked open if using AutoClean valve.
E=03	Sprayer stops. Engine is running.	Pressure transducer faulty, bad connection or broken wire.	Check transducer connections and wire. Replace transducer or control board, if necessary.
E=05	Sprayer stops. Engine is running.	High clutch current	<ol style="list-style-type: none"> <li>1. Check clutch 7-pin bulk-head connector. Clean contacts.</li> <li>2. <math>1.7 \pm 0.2\Omega</math> across clutch field at 70°F</li> <li>3. Replace clutch field assembly</li> </ol>
E=06	Sprayer stops. Engine is running. Display alternates E=06.	High clutch temperature	<ol style="list-style-type: none"> <li>1. If clutch is new, let sprayer cool down and then restart</li> <li>2. Inspect clutch. Replace clutch if there is excessive wear.</li> <li>3. Remove pump pin, separate pinion housing from clutch housing. Rotate rotor clockwise to check for excessive drag.</li> </ol>
E=07	Sprayer stops. Engine is running.	Pressure greater than 2000 psi (138 bar, 14 MPa) while in Flush Timer Mode	Chase paint from lines before running in flush timer mode. Make sure spray gun is triggered and prime valve is open when using AutoClean

### After a fault, follow these steps to restart sprayer:

1. Correct fault condition
2. Turn sprayer OFF
3. Turn sprayer ON

# Displacement Pump

## Removal

See manual 309277 for pump repair instructions.

1. Flush pump.
2. Fig. 9. Cycle pump with piston rod (222) in lowest position.
3.  Relieve pressure; page 4.
4. Fig. 9. Remove suction tube (30) and hose (33).

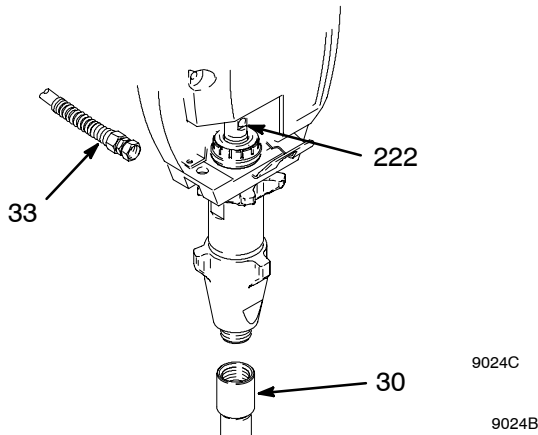

**Fig. 9**  
**Repair**

## Installation

### **WARNING**

If pin works loose, parts could break off due to force of pumping action. Parts could project through the air and result in serious injury or property damage. Make sure pin (101) and retaining clip (71a) are properly installed. See Detail A. Fig. 10.

### **CAUTION**

If the pump locknut loosens during operation, the threads of the bearing housing will be damaged. Make sure locknut is properly tightened.

1. Fig. 12. Pull piston rod out 1.0 in. Screw in pump until holes in housing plates and piston rod align.

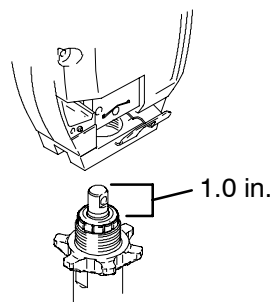

**Fig. 12**

5. Fig. 10. Use screwdriver to push out pump pin (101).

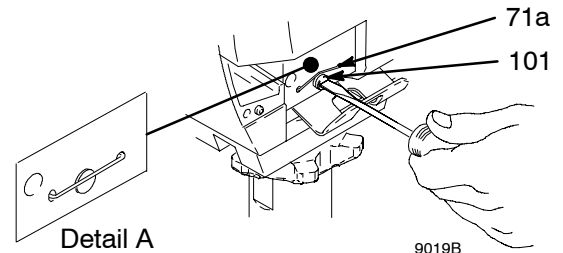

**Fig. 10**

6. Fig. 11. Loosen locknut by hitting firmly with a 20 oz (maximum) hammer. Unscrew pump.

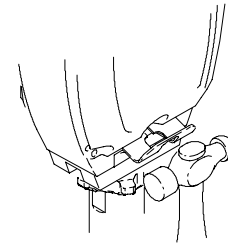

**Fig. 11**

2. Fig. 10. See Detail A. Push pin (101) into hole until retaining clip (71a) snaps over pin.

Fig. 13. Screw jam nut down onto pump until nut stops. Screw pump up into pump plate until it stops. Back off pump one full turn and align pump outlet to back. Tighten jam nut by hand, then tap 1/8 to 1/4 turn with a 20 oz (maximum) hammer to approximately 75 ±5 ft-lb (102 N·m).

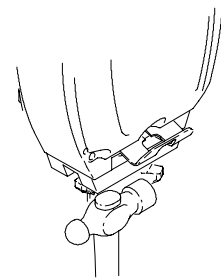

**Fig. 13**

- Fig. 14. Fill packing nut with Graco TSL until fluid flows onto the top of seal.

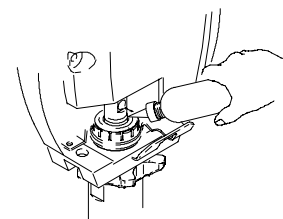

**Fig. 14**

# Displacement Pump

## Pump Pin Clip

### Removal

1. Remove pump (85).
2. Remove two bolts (107), washers (79), pump bracket (110), pail hook (90) and shield (113).
3. Fig. 10. Remove clip (71a).

### Installation

1. Fig. 10. Install clip (71a).
2. Install shield (113), pail hook (90) and pump bracket (110) with two washers (79) and bolts (107). Torque bolts to 40 ft-lb (54 N•m).
3. Install pump (85).



# Parts List & Drawing - Pinion Assembly

## Ref No. 8 and 71

### Ref No. 8: Pinion Housing Assembly 245400

### Ref No. 71: Drive Housing Assembly 245444

Ref No.	Part No.	Description	Qty	Ref No.	Part No.	Description	Qty
8a	245266	PINION HOUSING, COIL	1	71		DRIVE HOUSING	1
8b	105489	PIN	2	71a	194060	RETAINING CLIP, pump pin	1
8d	241114	PINION SHAFT		71b	193656	CAM FOLLOWER PLATE	1
8e	112770	RETAINING RING, large		71c	114691	CAM FOLLOWER BEARING	2
				71d	114828	RETAINER CLIP	2
				71g	114697	WASHER	1
				71h	114698	WASHER	1
				101	195523	PIN	1

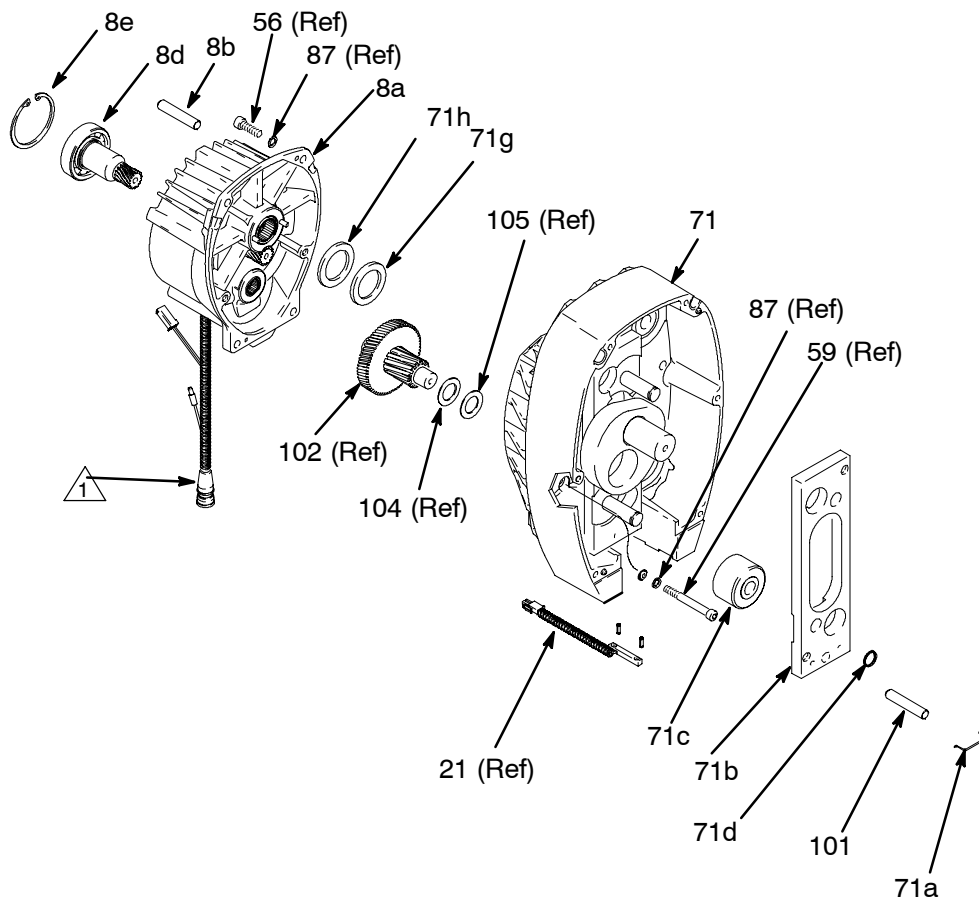

9046C

△ Pinion housing/coil assembly (8a) includes clutch field and all bearings, pins and o-rings

# Parts Drawing - Sprayers

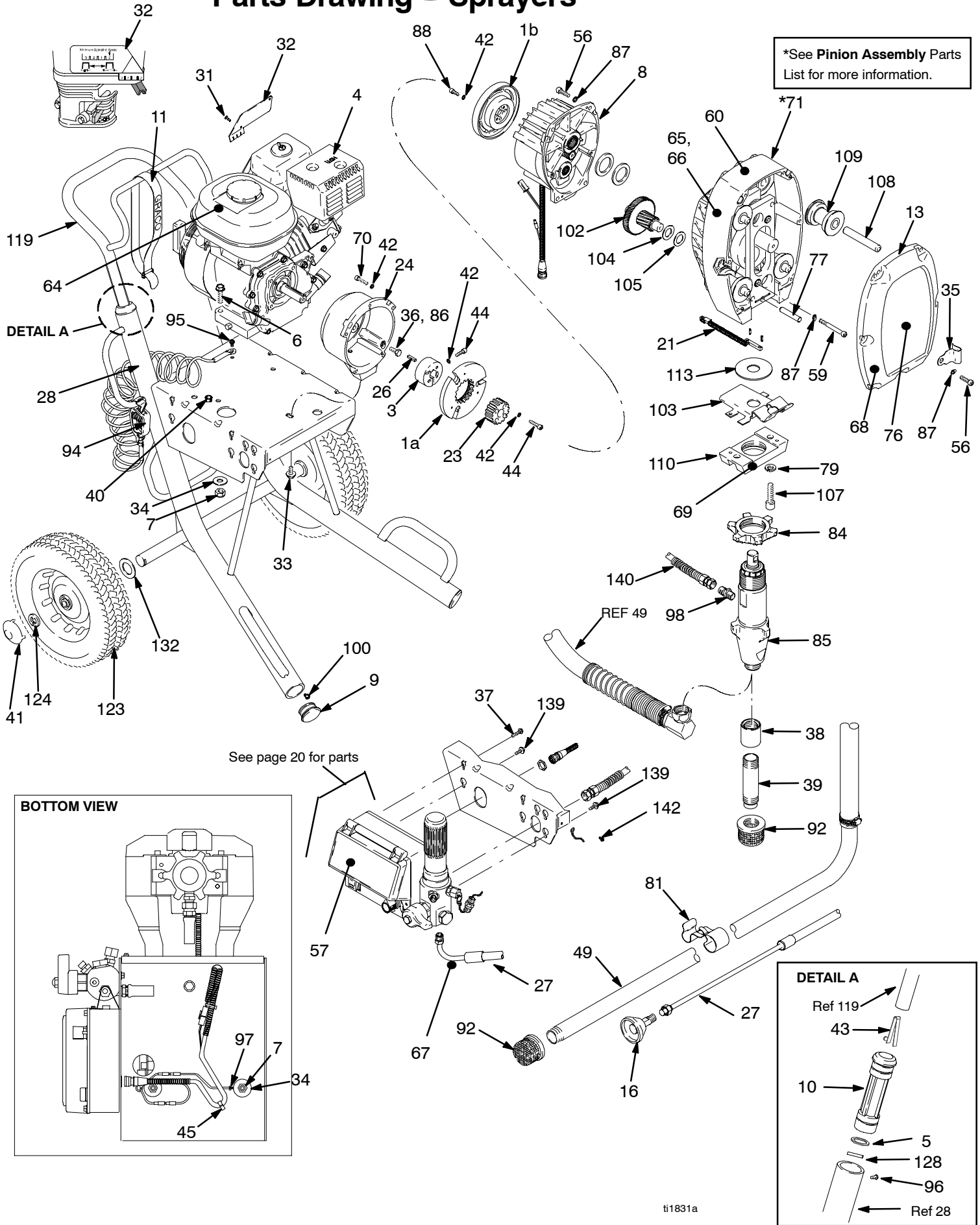

\*See Pinion Assembly Parts List for more information.

See page 20 for parts

BOTTOM VIEW

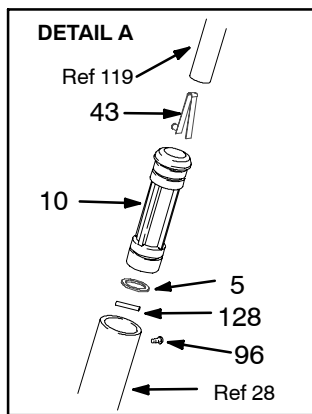

ti1831a

# Parts List

## Models 233718, 233719

Ref. No.	Part No.	Description	Qty.	Ref. No.	Part No.	Description	Qty.
1	241113	<b>CLUTCH, ASSEMBLY</b> includes 1a, 1b, 23, 42, 44, 88,	1	64▲	194126	LABEL, warning	1
1a		ARMATURE, clutch	1	65▲	194127	LABEL, warning	1
1b		ROTOR	1	66▲	194317	LABEL, danger, English	1
3	193680	COLLAR, shaft	1	67▲	195119	LABEL, warning tag	1
4	114530	ENGINE, gas, 5.5 HP, Honda	1	68▲	195519	LABEL, caution	1
5	183350	WASHER	2	69▲	192840	LABEL, warning	1
6	110837	SCREW, flange, hex	2	70	100644	SCREW, cap, sch	5
7	110838	NUT, lock	2	71	245444	<b>DRIVE HOUSING;</b> Parts page 17	1
8	245400	<b>PINION ASSEMBLY;</b> Parts page 17	1	76	198653	LABEL, identification	1
9	193682	PLUG, tube	2	77	195523	PIN, PUMP	1
10	191084	SLEEVE, cart	2	79	100018	WASHER, lock, spring	2
11	114271	STRAP, retaining	1	81	196723	CLIP, spring, Lo-Boy only	1
13	241536	COVER, assembly	1	84	193394	NUT, retaining	1
16	241920	DEFLECTOR, threaded	1	85	246257	<b>DISPLACEMENT PUMP;</b> Manual 309277	1
21	116806	SWITCH, reed w/conn	1	86	100214	WASHER, lock	4
24	193531	<b>CLUTCH HOUSING</b>	1	87	104008	WASHER, lock, spring	12
26	183401	KEY, parallel	1	88	101682	SCREW, cap, sch	4
27	246331	HOSE, drain, Lo-Boy	1	92	189920	STRAINER	1
	244240	HOSE, drain, Hi-Boy	1	94	237686	CLAMP, grounding assy	1
28	245164	FRAME, cart GMAX 7900	1	95	112798	SCREW, thread form, hex hd	1
31	113084	RIVET, blind	2	96	108795	SCREW, mach, pnh	4
32	192014	PLATE, indicator	1	97	240997	CONDUCTOR, ground	4
33	113802	SCREW	1	98	162485	FITTING, nipple, adapter	3
34	108851	WASHER	2	100	114984	SCREW, tapping, phil pan hd	2
35	197124	CLIP	1	102	241539	GEAR, combination	1
36	108842	SCREW	4	103	241540	<b>REPAIR KIT, HOOK, PAIL</b> (includes item 113)	1
37	198904	SCREW, #8	2				
38	114967	COUPLING, Hi-Boy only	1	104	114699	WASHER, thrust	1
39	198122	TUBE, Hi-Boy only	1	105	114672	WASHER, thrust	1
40	114678	GROMMET	1	107	110343	SCREW, cap, sch.	2
41	104811	CAP, hub	2	108	114695	PIN, dowel	4
42	105510	WASHER, lock, spring (hi-clr)	15	109	241322	ROLLER, assembly	4
43	112827	BUTTON, snap	2	110	194118	BRACKET, pump	1
44	108803	SCREW, hex, socket head	6	113	195377	SHIELD, paint	1
45	114687	CLIP	1	119	245245	HANDLE, cart	1
49	245249	TUBE, suction, 30 gal (assembly)	1	123	198720	WHEEL, semi-pneumatic 12 in.	2
56	101864	SCREW, cap sch	10	124	198723	AXLE, clip	2
57	196670	LABEL, crt1 box cover	1	128	108068	PIN, spring straight	2
59	114693	SCREW, cap, socket hd	2	132	116891	WASHER	2
60	290228	LABEL, caution	1	139	112774	SCREW, machine	1
				140	198847	HOSE, coupled	1
				141	109575	SCREW, threadforming	2

▲ Replacement Danger and Warning labels, tags, and cards are available at no cost.

# Parts Drawing - Sprayer

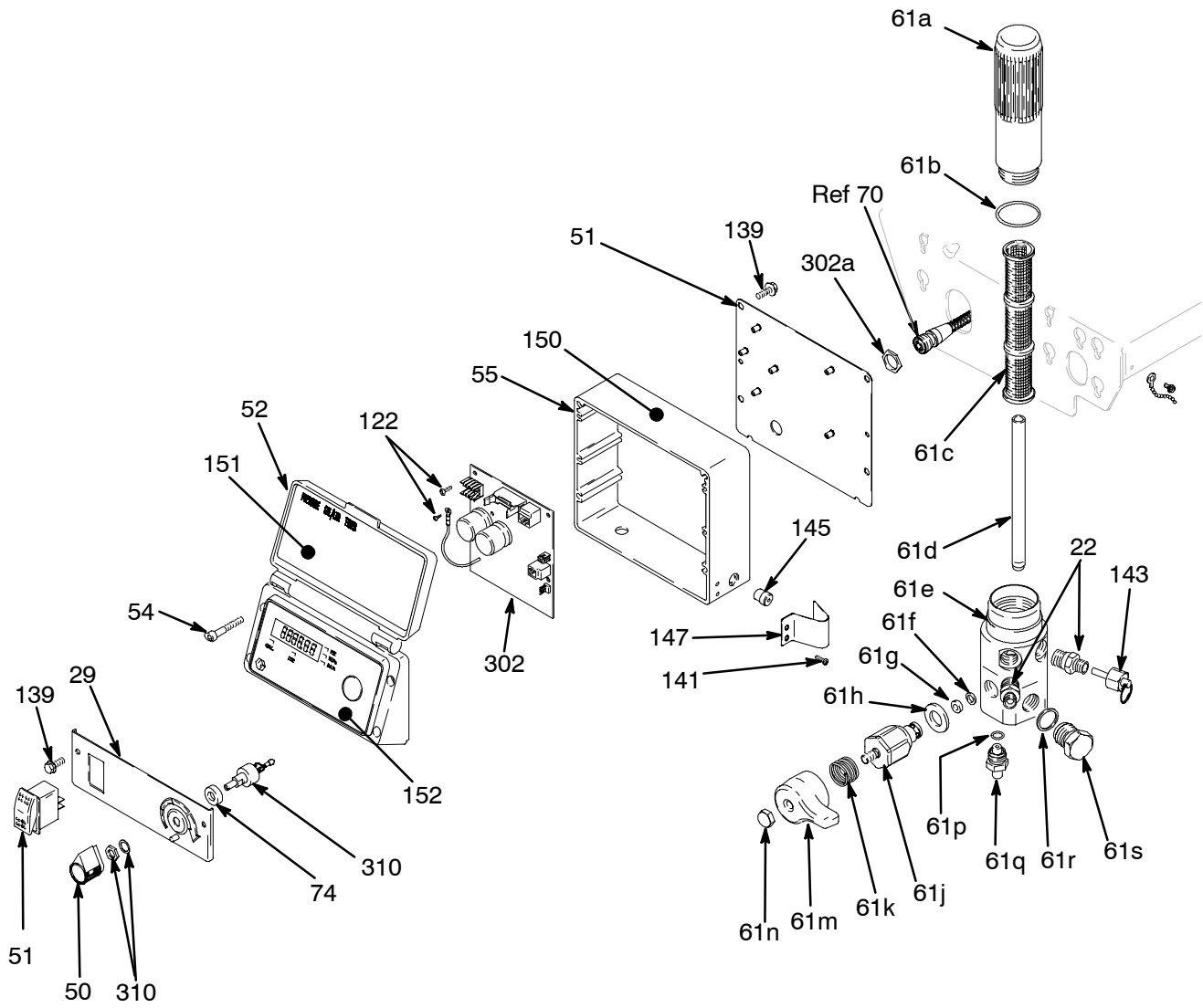

ti1838a

# Parts List - Sprayer

REF NO.	PART NO.	DESCRIPTION	QTY	REF NO.	PART NO.	DESCRIPTION	QTY
22	162485	ADAPTER	2	61q	243222	TRANSDUCER, pressure control includes 61p	1
29	198553	PANEL, control	1	61r	197055	GASKET, plug	1
50	116167	KNOB, potentiometer	1	61s	196781	PLUG, AutoClean	1
51	116752	SWITCH, rocker, (spst)	1	74	198650	SPACER, shaft	1
52	245393	DIGITAL DISPLAY Includes 54, 57, 151, 152	1	122	114331	SCREW, pnhd 6-32	6
53	198534	PLATE, control	1	133	109575	SCREW, threadformer	2
54	116252	SCREW, #8 taptite, phil	4	139	112774	SCREW, mach	4
55	198548	HOUSING, control	1	143	245475	PLUG, packless	1
		FILTER, fluid	1	145	114296	BUSHING, step	1
61	245396	KIT, repair, filter (includes 61a-61s)	1	147	198994	GUARD, transducer	1
61a	196675	BOWL, filter	1	150▲	189246	LABEL, warning	1
61b	104361	O-RING	1	151	198884	LABEL, instruction, GMax	1
61c	244067	STRAINER, mesh, 60	1	152	198648	LABEL, GMax, LCD	1
61d	196786	TUBE, diffuser	1	<b>302</b>	<b>245394</b>	<b>BOARD, PC</b> Includes 302a	<b>1</b>
61e	245401	KIT, repair, filter base	1	302a		NUT, nylon	1
61f	193710	SEAL, valve	1	310	241443	POTENTIOMETER, pressure control	1
61g	193709	SEAT, valve	1				
61h	114797	GASKET	1				
61j	245103*	VALVE	1				
61k	114708	SPRING, compression	1				
61m	194102	HANDLE, valve	1				
61n	114688	NUT, cap, hex hd	1				
61p	111457	O-RING	1				

\* Drain valve replacement kit 245103 includes 61f, 61g, 61h, 61k, 61m, and 61n.

▲ Replacement Danger and Warning labels, tags, and cards are available at no cost.

## Pressure Control Wiring Diagram

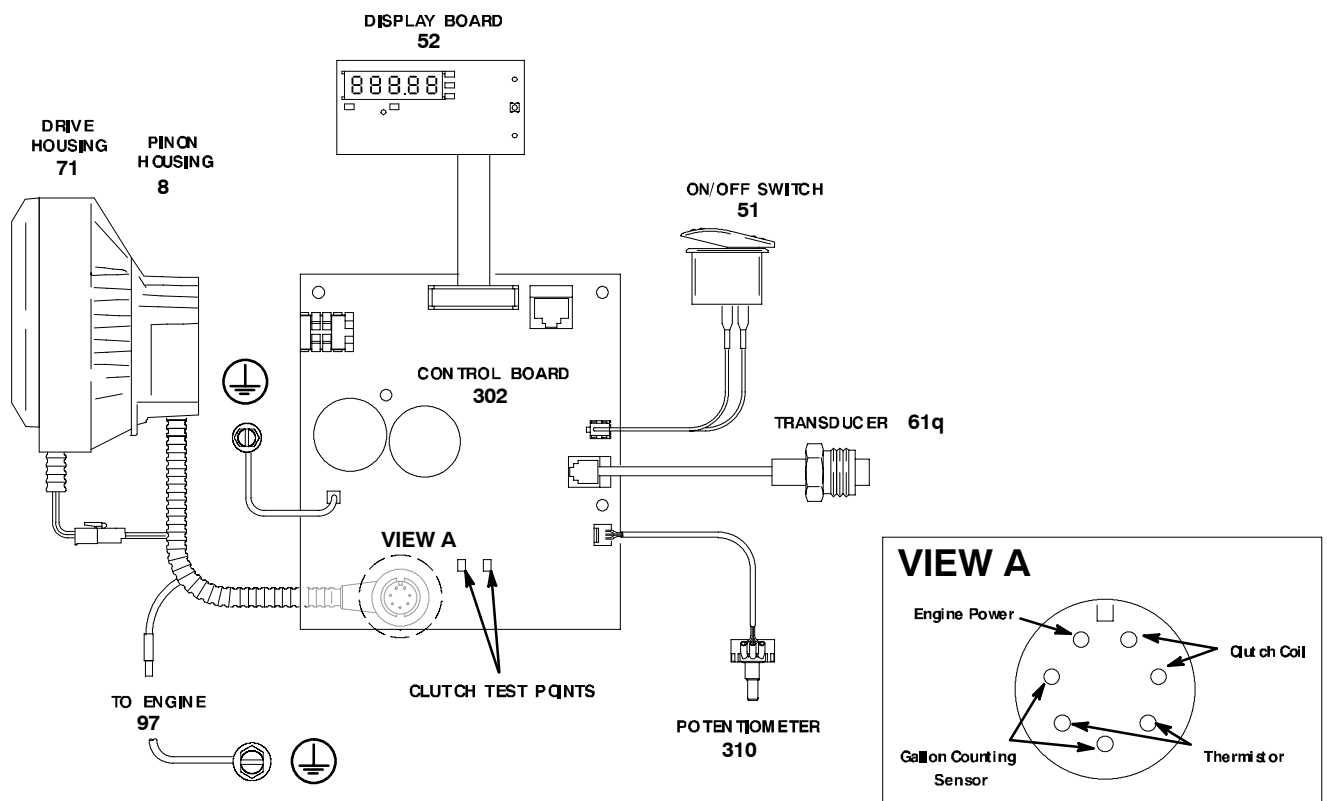

Fig. 15

ti1834a

# Parts List/Drawing - Sprayers with RAC 5 Tip, Gun & Hose

## Models 233720, 233721

Includes items 201 to 204

Ref No.	Part No.	Description	Qty
201	233719	Hi-Boy Sprayer See parts list on page 19	1
	233718	Lo-Boy Sprayer See parts list on page 19	1
202	240797	HOSE, grounded, nylon; 3/8 in. ID; cpld 3/8 npsm(fbe); 50 foot (15 m); spring guards both ends 3300 psi (227 bar, 27.7 MPa)	1
203	238358	HOSE, grounded, nylon; 3/16 in. ID; cpld 1/4 npsm(m) x 1/4 npsm(f) swivel; 3 foot (0.9 m); spring guards both ends	1
204	246220	CONTRACTOR SPRAY GUN Includes RAC X 517-size SwitchTip™ and HandTite™ Guard See 309639 for parts	1
205	159841	ADAPTER	1

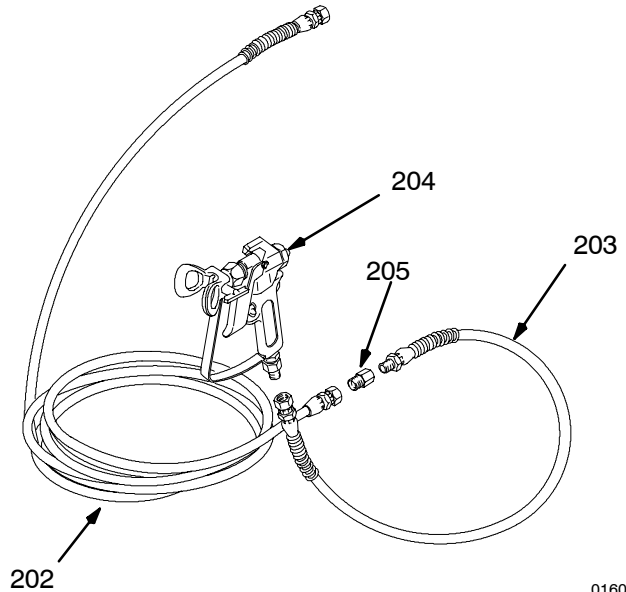

## Accessories

### DANGER LABELS

An English language DANGER label is on your sprayer. If you have painters who do not read English, order one of the following labels to apply to your sprayer. The drawing shows the best placement of these labels for good visibility.

Order the labels from your Graco distributor.

French	194931
Spanish	194932
German	194933
Greek	194934
Korean	194935
English	194125

Apply other language here

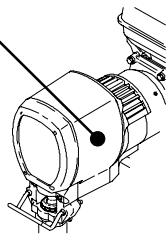

03497A

### Displacement Pump Repair Kits

Packing repair kits.

**GMax 7900**

**240916**

# Technical Data

Honda GX160 Engine  
Power Rating @ 3700 rpm  
ANSI ..... 5.5 Horsepower  
DIN 6270B/DIN 6271  
NA ..... 2.9 Kw - 4.0 Ps  
NB ..... 3.6 Kw - 4.9 Ps  
Maximum working pressure ..... 3300 psi  
(227 bar, 22.7 MPa)  
Noise Level  
Sound power ..... 105 dBa  
per ISO 3744  
Sound pressure ..... 96 dBa  
measured at 3.1 feet (1 m)  
Cycles/gallon (liter) ..... 69 (18)

Maximum delivery rating ..... 2.1 gpm (7.9 liter/min)  
Maximum tip size ..... 1 gun with 0.046 in. tip  
2 guns with 0.033 in. tip  
3 guns with 0.026 in. tip  
4 guns with 0.022 in. tip  
Inlet paint strainer ..... 16 mesh (1190 micron)  
stainless steel screen, reusable  
Outlet paint filter ..... 60 mesh (250 micron)  
stainless steel screen, reusable  
Pump inlet size ..... 3/4 in. npt (m)  
Fluid outlet size ..... 3/8 npsm from fluid filter  
Wetted parts ..... zinc-plated carbon steel,  
PTFE, Nylon, UHMW polyethylene,  
Viton®, Delrin®, leather, aluminum, tungsten carbide,  
nickel and zinc-plated carbon steel, stainless steel,  
chrome plating, PEEK

**NOTE:** Delrin®, PTFE, Viton® are trademarks of the DuPont Company.

## Dimensions

### Model 233718, 233720

#### Lo-Boy Cart without hose or gun

Weight (dry, without packaging) ..... 180 lb (82.1 kg)  
Height ..... 41 in. (104.1 cm)  
Length ..... 39 in. (99.1 cm)  
Width ..... 22 in. (55.9 cm)

### Model 233719, 233721

#### Hi-Boy without hose or gun

Weight (dry, without packaging) ..... 175 lb (79.4 kg)  
Height ..... 41 in. (104.1 cm)  
Length ..... 39 in. (99.1 cm)  
Width ..... 22 in. (55.9 cm)

# Graco Standard Warranty

Graco warrants all equipment manufactured by Graco and bearing its name to be free from defects in material and workmanship on the date of sale by an authorized Graco distributor to the original purchaser for use. With the exception of any special, extended, or limited warranty published by Graco, Graco will, for a period of twelve months from the date of sale, repair or replace any part of the equipment determined by Graco to be defective. This warranty applies only when the equipment is installed, operated and maintained in accordance with Graco's written recommendations.

This warranty does not cover, and Graco shall not be liable for general wear and tear, or any malfunction, damage or wear caused by faulty installation, misapplication, abrasion, corrosion, inadequate or improper maintenance, negligence, accident, tampering, or substitution of non-Graco component parts. Nor shall Graco be liable for malfunction, damage or wear caused by the incompatibility of Graco equipment with structures, accessories, equipment or materials not supplied by Graco, or the improper design, manufacture, installation, operation or maintenance of structures, accessories, equipment or materials not supplied by Graco.

This warranty is conditioned upon the prepaid return of the equipment claimed to be defective to an authorized Graco distributor for verification of the claimed defect. If the claimed defect is verified, Graco will repair or replace free of charge any defective parts. The equipment will be returned to the original purchaser transportation prepaid. If inspection of the equipment does not disclose any defect in material or workmanship, repairs will be made at a reasonable charge, which charges may include the costs of parts, labor, and transportation.

**THIS WARRANTY IS EXCLUSIVE, AND IS IN LIEU OF ANY OTHER WARRANTIES, EXPRESS OR IMPLIED, INCLUDING BUT NOT LIMITED TO WARRANTY OF MERCHANTABILITY OR WARRANTY OF FITNESS FOR A PARTICULAR PURPOSE.**

Graco's sole obligation and buyer's sole remedy for any breach of warranty shall be as set forth above. The buyer agrees that no other remedy (including, but not limited to, incidental or consequential damages for lost profits, lost sales, injury to person or property, or any other incidental or consequential loss) shall be available. Any action for breach of warranty must be brought within two (2) years of the date of sale.

Graco makes no warranty, and disclaims all implied warranties of merchantability and fitness for a particular purpose in connection with accessories, equipment, materials or components sold but not manufactured by Graco. These items sold, but not manufactured by Graco (such as electric motors, switches, hose, etc.), are subject to the warranty, if any, of their manufacturer. Graco will provide purchaser with reasonable assistance in making any claim for breach of these warranties.

In no event will Graco be liable for indirect, incidental, special or consequential damages resulting from Graco supplying equipment hereunder, or the furnishing, performance, or use of any products or other goods sold hereto, whether due to a breach of contract, breach of warranty, the negligence of Graco, or otherwise.

## **FOR GRACO CANADA CUSTOMERS**

The parties acknowledge that they have required that the present document, as well as all documents, notices and legal proceedings entered into, given or instituted pursuant hereto or relating directly or indirectly hereto, be drawn up in English. Les parties reconnaissent avoir convenu que la rédaction du présente document sera en Anglais, ainsi que tous documents, avis et procédures judiciaires exécutés, donnés ou intentés à la suite de ou en rapport, directement ou indirectement, avec les procédures concernées.

## **ADDITIONAL WARRANTY COVERAGE**

Graco does provide extended warranty and wear warranty for products described in the "Graco Contractor Equipment Warranty Program".

## **Graco Phone Number**

**TO PLACE AN ORDER**, contact your Graco distributor, or call **1-800-690-2894** to identify your closest distributor.

*All written and visual data contained in this document reflects the latest product information available at the time of publication.  
Graco reserves the right to make changes at any time without notice.*

MM 309412

**Graco Headquarters:** Minneapolis  
**International Offices:** Belgium, China, Japan, Korea

**GRACO INC. P.O. BOX 1441 MINNEAPOLIS, MN 55440-1441**

**www.graco.com**

PRINTED IN USA 309412E 1/2002 Rev. 08/2009