

INSTRUCTIONS – INSTRUCTIONS INSTRUCTIES – ANLEITUNG



309092

Rév. D
Rev. D

Silver Airless Spray Gun; Pistolet pulvérisateur sans air Silver; Silver airless spuitpistool; Silver Airless-Spritzpistole

5000 psi (345 bar, 34.5 MPa) Maximum Working Pressure
Pression de service maximum 5000 psi (345 bar, 34,5 MPa)
Maximum werkdruk 5000 psi (345 bar, 34,5 MPa)
Zulässiger Betriebsüberdruck 5000 psi (345 bar, 34,5 MPa)

235460, C

Standard (nonreversing) Driplless™ Tip Guard; 2-finger trigger. No spray tip; order separately.
Norme (non réversible) Garde-buse Driplless™; gâchette de 2 doigts. Sans buse; commander séparément.
Standaard (niet-omkerende) Driplless™ -tipbeschermer; tweevinger-trekker. Zonder spuittip; afzonderlijk bestellen.
Standardmäßiger (nicht umkehrbarer) tropffreier Düsenschutz; 2-Fingerabzug. Ohne Spritzdüse; separat zu bestellen.

235461, B

Standard (nonreversing) Driplless™ Tip Guard; 4-finger trigger. No spray tip; order separately.
Norme (non réversible) Garde-buse Driplless™; gâchette de 4 doigts. Sans buse; commande séparément.
Standaard (niet-omkerende) Driplless™ -tipbeschermer; viervinger-trekker. Zonder spuittip; afzonderlijk bestellen.
Standardmäßiger (nicht umkehrbarer) tropffreier Düsenschutz; 4-Fingerabzug. Ohne Spritzdüse; separat zu bestellen.

235462, C

Fine Finish. Standard (nonreversing) Driplless™ Tip Guard; 2-finger trigger. No spray tip; order separately.
Finition Supérieure. Norme (non réversible) Garde-buse Driplless™; gâchette de 2 doigts. Sans buse; commander séparément.
Fine-finish. Standaard (niet-omkerende) Driplless™ -tipbeschermer; tweevinger-trekker. Zonder spuittip; afzonderlijk bestellen.
Feine Zerstäubung. Standardmäßiger (nicht umkehrbarer) tropffreier Düsenschutz; 2-Fingerabzug. Ohne Spritzdüse; separat zu bestellen.

243283, A

HandTite™ Tip Guard, 517 RAC™ 5 SwitchTip™; 2-finger trigger.
Garde HandTite™, buse 517 RAC™ 5 SwitchTip™; gâchette de 2 doigts.
HandTite™ -tipbeschermer, 517 RAC™ 5 SwitchTip™; tweevinger-trekker.
HandTite™ Düsenschutz, 517 RAC™ 5 Umkehrdüse™; 2-Fingerabzug.

235464, C

Heavy Duty RAC Tip Guard, 617 SwitchTip; 2-finger trigger.
Résistant RAC Garde-buse, 617 SwitchTip; gâchette de 2 doigts.
Heavy-duty RAC-tipbeschermer, 617 SwitchTip; tweevinger-trekker.
Heavy Duty Umkehr-Düsenschutz, 617 SwitchTip; 2-Fingerabzug.

238591, A

Heavy Duty RAC Tip Guard, 619 SwitchTip; 4-finger trigger.
Résistant RAC Garde-buse, 619 SwitchTip; gâchette de 4 doigts.
Heavy-duty RAC-tipbeschermer, 619 SwitchTip; viervinger-trekker.
Heavy Duty Umkehr-Düsenschutz, 619 SwitchTip; 4-Fingerabzug.

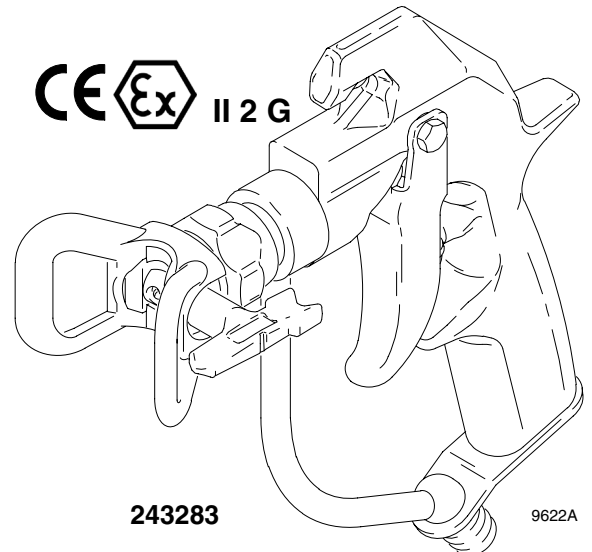

All models not available in all countries.
Tous les modèles ne sont pas disponibles dans tous les pays.
Niet alle modellen zijn in alle landen verkrijgbaar.
Nicht alle Modelle sind in allen Ländern verfügbar.

! WARNING

Fire and explosion hazard: Solvent and paint fumes can ignite or explode.

To help prevent a fire and explosion:

● **Use in an extremely well ventilated area.**

● Eliminate all ignition sources; such as pilot lights, cigarettes and static arcs from plastic drop cloths. Do not plug or unplug power cords or turn lights on or off in spray area.

● Ground Sprayer, object being sprayed, paint and solvent pails.

● Hold gun firmly to side of grounded pail when triggering into pail.

● Use only conductive airless paint hose.

● Do not use 1,1,1-trichloroethane, methylene chloride, other halogenated hydrocarbon solvents or fluids containing such solvents in pressurized aluminum equipment. Such use could result in a chemical reaction, with the possibility of explosion.



! MISE EN GARDE

Risques d'incendie et d'explosion: Les vapeurs de solvant et de peinture peuvent s'enflammer ou causer une explosion.

Pour empêcher tout incendie et explosion:

● **N'utiliser ce matériel que dans des locaux extrêmement bien aérés.**

● Éliminer toutes les sources de feu, comme les veilleuses, cigarettes et les arcs statiques provenant de bâches plastique. Ne pas brancher ou débrancher de cordon électrique ou allumer ou éteindre la lumière sur un site de pulvérisation.

● Raccorder le pulvérisateur, l'objet à peindre et les seaux de peinture et de solvant à la terre.

● Appuyer le pistolet contre le côté du seau mis à la terre quand on pulvérise dans le seau.

● N'utiliser que des flexibles de peinture conducteurs sans air.

● Ne jamais utiliser de trichloroéthane-1,1,1, de chlorure de méthylène, d'autres solvants à base d'hydrocarbures halogénés ni de fluides contenant de tels solvants dans une unité sous pression en aluminium. Cela pourrait provoquer une réaction chimique avec risque d'explosion.

Fluid injection and high pressure hazard: High pressure spray or leaks can inject fluid into the body.

To help prevent injection, always:

● Engage trigger safety latch when not spraying.

● Keep clear of nozzle and leaks.

● Never spray without a tip guard.

● Do **PRESSURE RELIEF** if you stop spraying or begin servicing sprayer.

● Do not use components rated less than sprayer *Maximum Working Pressure*.

● Never allow children to use this unit.

● Brace yourself; gun may recoil when triggered.

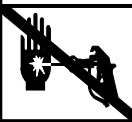

Risques d'injection, haute pression danger: Une pulvérisation ou des fuites à haute pression peuvent provoquer une injection de produit dans le corps.

Pour éviter toute injection, toujours:

● Verrouiller la gâchette à chaque arrêt de la pulvérisation.

● Se tenir à l'écart de la buse et des fuites.

● Ne jamais se servir du pistolet pour pulvériser sans garde de buse.

● Effectuer une **DÉCOMPRESSION** à chaque arrêt de la pulvérisation ou avant tout entretien.

● Ne pas utiliser d'éléments prévus pour une pression inférieure à la *pression de service maximum* du pulvérisateur.

● Ne jamais permettre à des enfants d'utiliser cet appareil.

● L'utilisateur doit être en position très stable; le pistolet peut reculer une fois déclenché.

Si du liquide sous haute pression est injecté sous la peau, la blessure peut avoir l'apparence "d'une simple coupure", mais c'est en fait une blessure sérieuse! Consulter un médecin immédiatement.

! WAARSCHUWING

Gevaar van brand en explosie: Dampen van oplosmiddel en verf kunnen tot ontbranding komen of exploderen.

Voorkom brand en explosie:

● **Werk alleen in zeer goed geventileerde ruimten.**

● Draai alle ontstekingsbronnen uit; denk aan waakvlammen, sigaretten en statische vonken van een dekkleed of afdekplastic. Steek geen stekkers in en haal geen stekkers uit stopcontacten in de ruimte waar gespoten wordt.

● Aard het spuittoestel, het te spuiten voorwerp, en de emmers met verf en oplosmiddel.

● Houd het pistool stevig tegen de zijkant van een geaarde emmer gedrukt terwijl u in de emmer spuit.

● Gebruik alleen geaarde slangen voor airless spuiten.

● Gebruik in aluminium apparatuur onder druk geen oplosmiddelen of spuitvloeistoffen die 1,1,1-trichloorethaan, methyleenchloride of andere gehalogeneerde koolwaterstoffen bevatten. Dit kan namelijk leiden tot chemische reacties, met kans op ontploffingen.

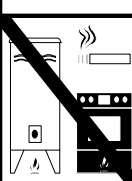

! WARNING

Brand- und Explosionsgefahr: Dämpfe von Lösemitteln und Lacken können sich entzünden oder explodieren.

Durch folgende Punkte kann die Brand- und Explosionsgefahr verringert werden:

● **Gerät nur in sehr gut belüfteten Räumen verwenden.**

● Mögliche Zündquellen, wie z.B. Dauerflammen, Zigaretten und statische Elektrizität von Plastik-Abdeckfolien, vermeiden. Im Spritzbereich kein Stromkabel ein- oder ausstecken und keinen Lichtschalter betätigen.

● Spritzgerät, Spritzobjekt sowie Material- und Lösemittelimer erden.

● Beim Spritzen in einen Eimer die Pistole fest an den geerdeten Eimer drücken.

● Nur einen elektrisch leitfähigen Airless-Materialschlauch verwenden.

● Niemals 1,1,1-Trichlorethan, Methylenchlorid, andere Lösemittel mit halogenisierten Kohlenwasserstoffen oder Materialien, die solche Lösemittel enthalten, in druckbeaufschlagten Aluminiumgeräten verwenden. Dies könnte zu einer chemischen Reaktion führen und in der Folge eine Explosion verursachen.

Gevaar van vloeistofinjectie en materiaal onder hoge druk:

Spuitmateriaal onder hoge druk, ook uit lekken, kan binnendringen in het lichaam.

Let altijd op de volgende punten, om injectie van materiaal te voorkomen:

● Zet de veiligheidsvergrendeling in de geblokkeerde stand wanneer er niet gespoten wordt.

● Blijf weg van de spuitmonden en van lekken.

● Spuit nooit zonder dat de tipbeschermer geplaatst is.

● Voer de **DRUKONTLASTPROCEDURE** uit als u ophoudt met spuiten of voor u begint met onderhoud aan de spuitapparatuur.

● Gebruik geen componenten met een lagere *maximum werkdruk dan die van dit spuitapparaat*.

● Laat kinderen nooit met dit apparaat werken.

● Zorg dat u stevig staat; het pistool kan een terugslag geven wanneer de trekker wordt ingetrokken.

Als materiaal onder hoge druk door de huid is binnengedrongen kan de verwonding eruitzien als een "gewone snijwond". Het is echter een ernstige verwonding! Roep meteen medische hulp in.

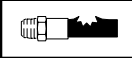

Gefahr durch Materialeinspritzung und Hochdruck: Durch Spritzer oder undichte Stellen kann Material mit hohem Druck in den Körper gespritzt werden.

Um Einspritzungen zu vermeiden, stets:

● Die Abzugssperre an der Pistole verriegeln, wenn nicht gespritzt wird.

● Abstand zur Düse und zu undichten Teilen halten!

● Niemals ohne Düsenschutz spritzen.

● Den **DRUCK ENTLASTEN**, wenn die Spritzarbeiten unterbrochen werden oder bevor Servicearbeiten am Spritzgerät durchgeführt werden.

● Keine Komponenten verwenden, die für einen geringeren Druck als den *zulässigen Betriebsüberdruck des Spritzgeräts ausgelegt sind*.

● Niemals Kinder an dieses Gerät lassen.

● Der Bediener muß beim Abziehen der Pistole auf einen guten Stand achten, da die Pistole beim Abziehen einen Rückstoß verursachen kann.

Wenn Material mit hohem Druck in die Haut eindringt, kann die dabei entstehende Wunde wie ein "einfacher Schnitt" aussehen. Tatsächlich ist es jedoch eine schwere Verletzung! In diesem Fall sofort einen Arzt aufsuchen.

CONTROLS / COMMANDES / BEDIENINGSFUNCTIES / REGLER

Trigger Lock / Verrouillage gâchette / Trekkervergrendeling / Abzugssperre



Tip Guard / Garde-buse
Tipbeschermer /
Düsenschutz

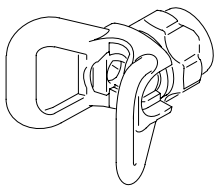

Trigger / Gâchette
Trekker / Abzug

Tip / Buse / Tip / Düse

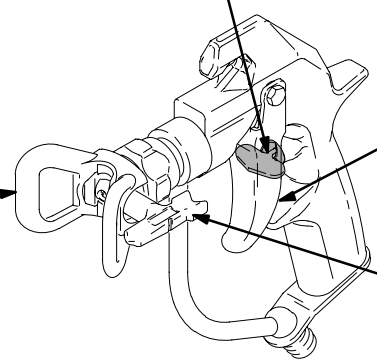
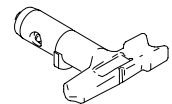

9622A

PRESSURE RELIEF / DÉCOMPRESSION DRUKONTLASTING / DRUCKENTLASTUNG



Follow 1–5 when you stop spraying.
Effectuer les opérations 1–5 lors d'un arrêt de la pulvérisation.
Volg stappen 1 t/m 5 als u ophoudt met spuiten.
Schritte 1–5 ausführen, wenn die Spritzarbeiten beendet werden.

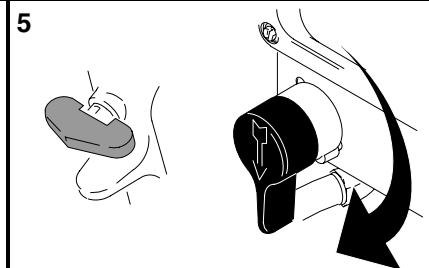
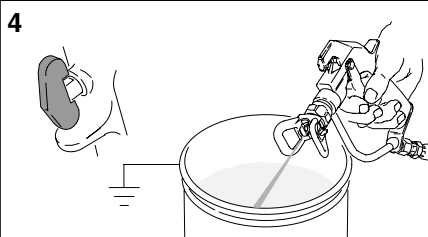
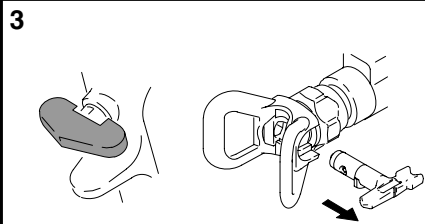
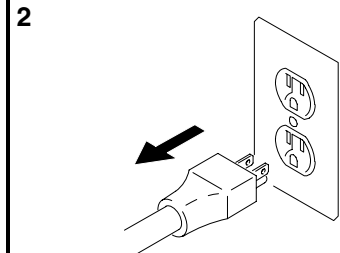
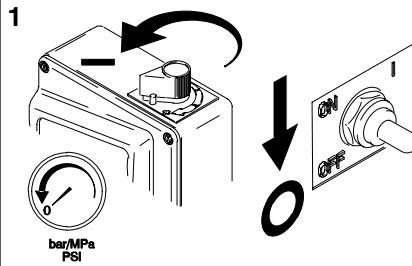

INSTALLATION / INSTALLATION / INSTALLATIE / INSTALLATION

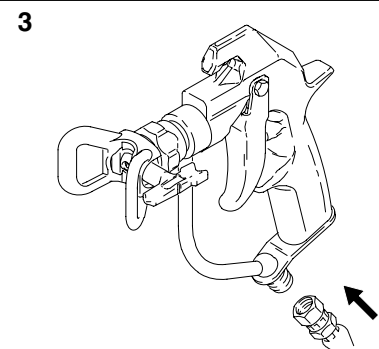
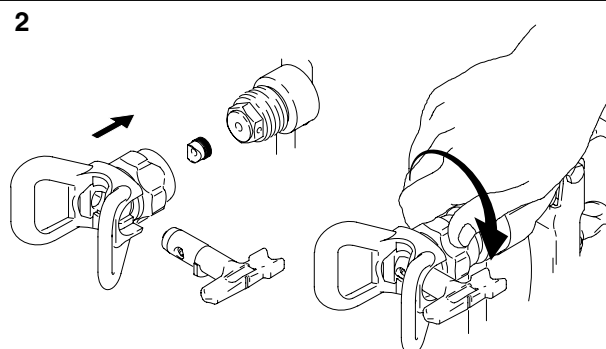

**ALIGN SPRAY / ALIGNER LE JET
HET SPUITEN AFREGELLEN / SPRITZBILD AUSRICHTEN**

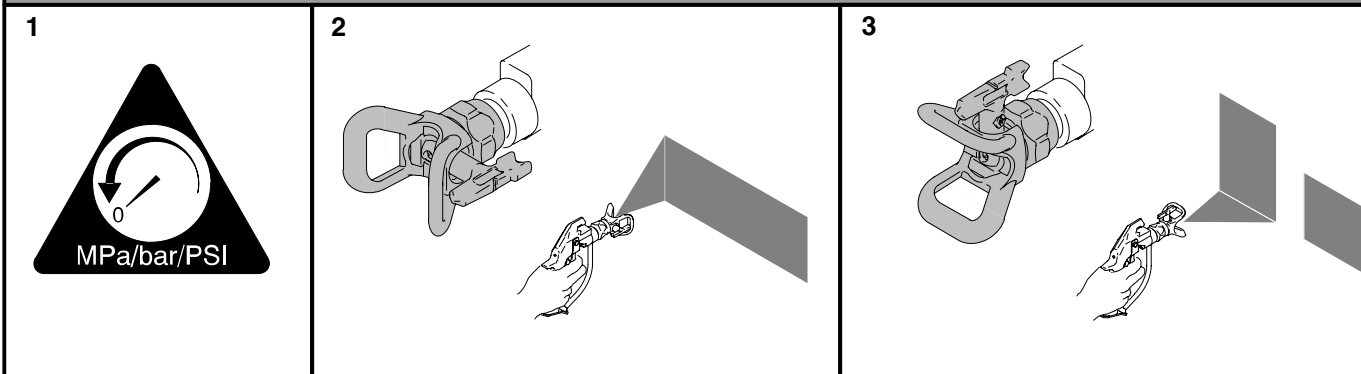

**ADJUST SPRAY / RÉGLER LE JET
AFSTELLEN SPUITPATROON / SPRITZBILD EINSTELLEN**

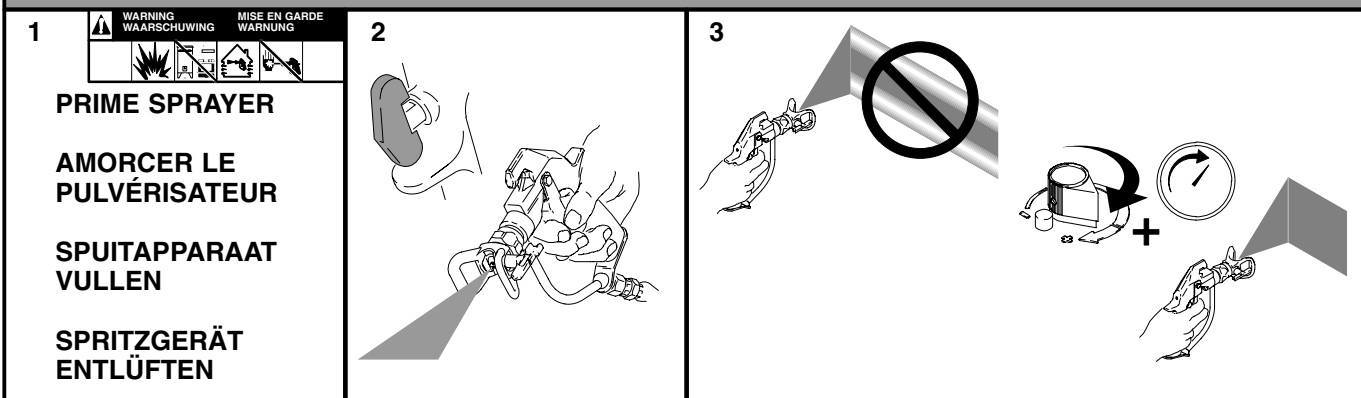

CLEAR CLOG / DÉBOUCHER LA BUSE / VERSTOPPING VERWIJDEREN / VERSTOPFUNG BESEITIGEN

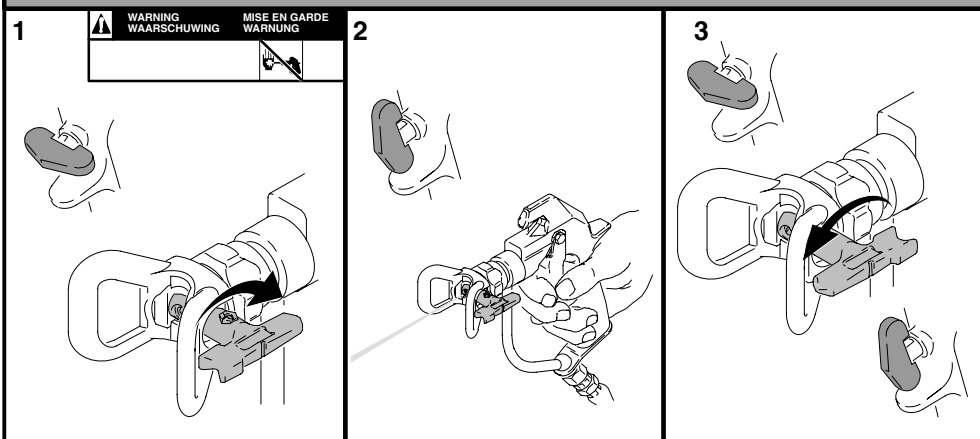

**CAUTION
ATTENTION
VOORZICHTIG
VORSICHT**



**REPLACE NEEDLE / REMPLACER LE POINTEAU
NAALD VERVERVANGEN / NADEL AUSWECHSELN**

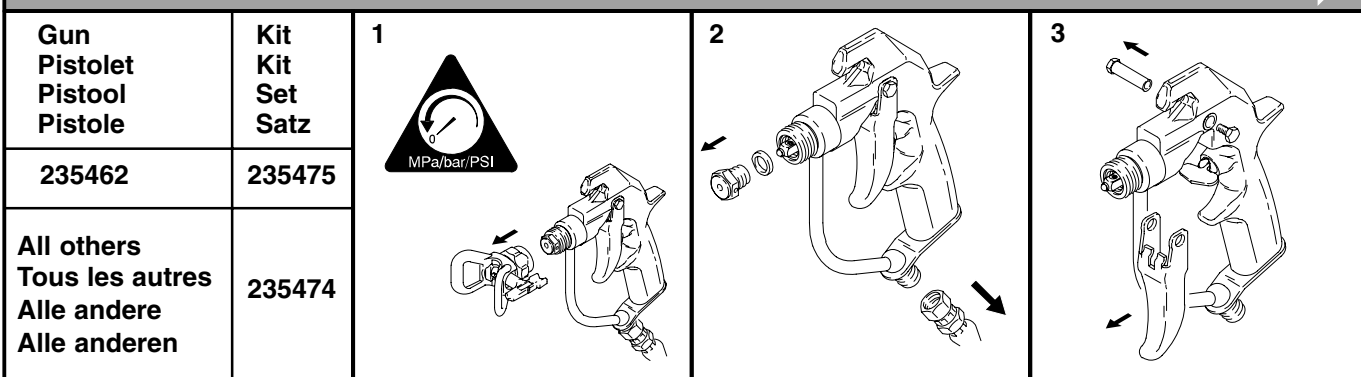

**REPLACE NEEDLE / REMPLACER LE POINTEAU
DE NAALD VERVANGEN / NADEL AUSWECHSELN**

4

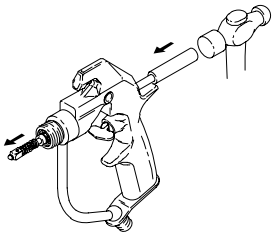

5

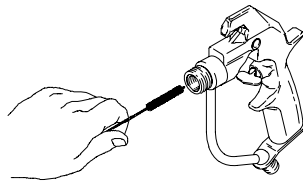

**CLEAN
NETTOYER
REINIGEN
REINIGEN**

6

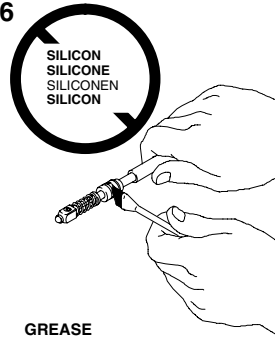

**GREASE
GRAISSER
INVETTEN
EINFETTEN**

7

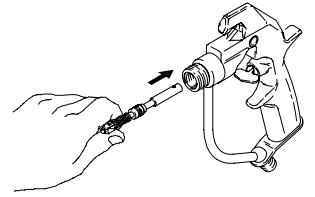

**NEW
NOUVEAU
NIEUW
NEU**

9

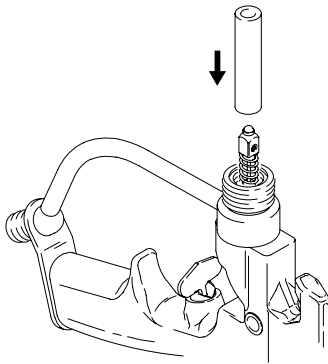

10

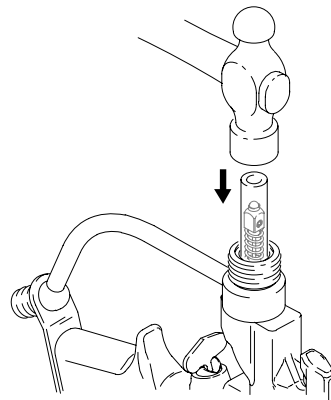

11

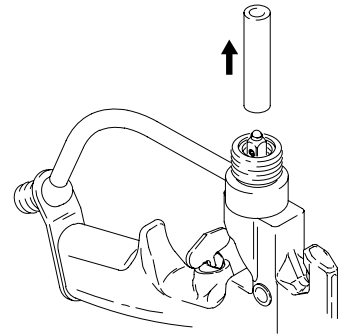

12

**GREASE
GRAISSER
INVETTEN
EINFETTEN**

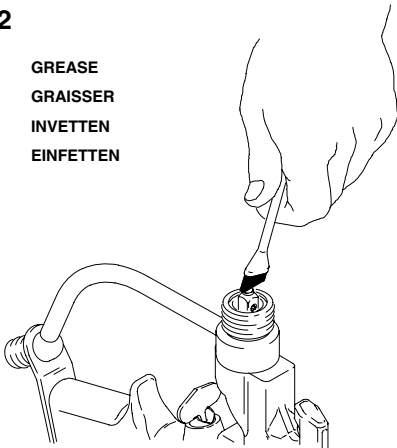

13

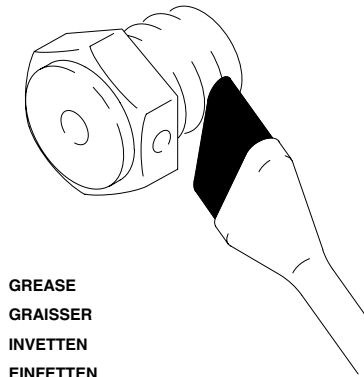

**GREASE
GRAISSER
INVETTEN
EINFETTEN**

14

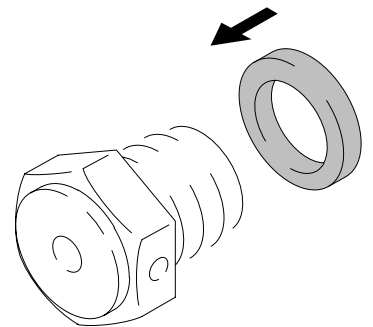

15

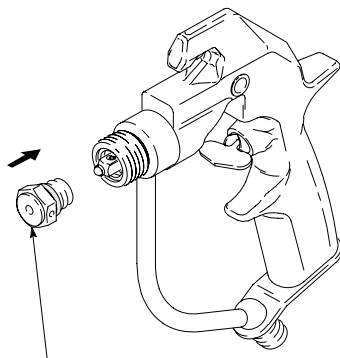

20–25 ft-lb / 27–34 N.m

16

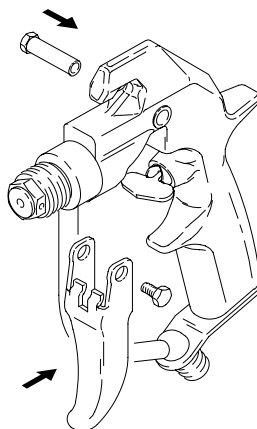



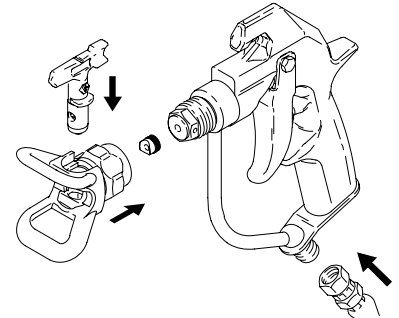

17

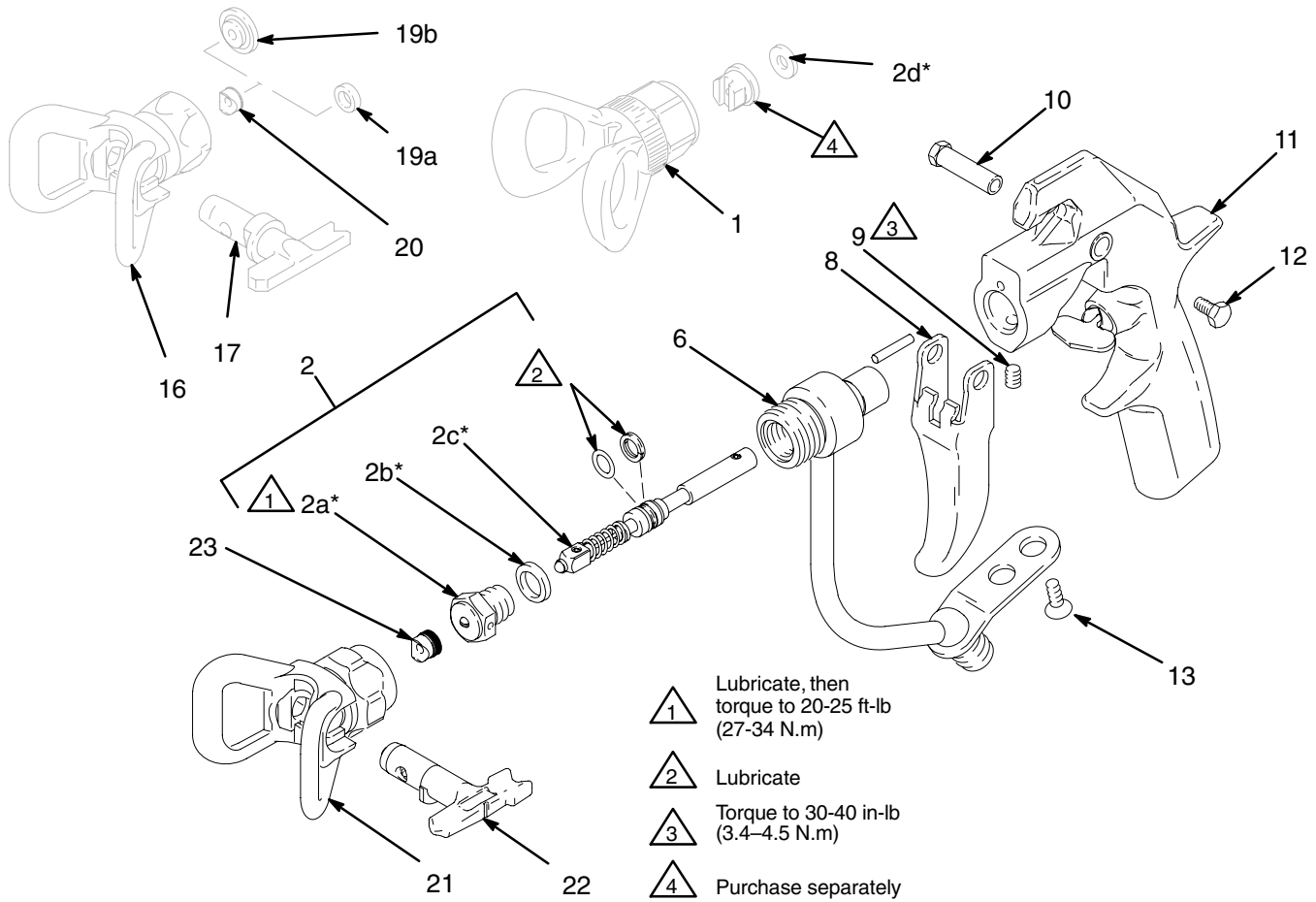

Parts / Pièces / Onderdelen / Teile



-  Lubricate, then torque to 20-25 ft-lb (27-34 N.m)
-  Lubricate
-  Torque to 30-40 in-lb (3.4-4.5 N.m)
-  Purchase separately

9626A

235460, C: Standard (non-reversing) DripLess™ Tip Guard: 2-finger trigger. *Includes items 1 to 15.*

235461, B: Standard (non-reversing) DripLess™ Tip Guard; 4-finger trigger. *Includes items 1 to 15.*

Ref No.	Part No.	Description	Qty.	Ref No.	Part No.	Description	Qty.
1	220251	STANDARD TIP GUARD	1	1	220251	STANDARD TIP GUARD	1
2	235474	NEEDLE KIT <i>Includes items 2a to 2d</i>	1	2	235474	NEEDLE KIT <i>Includes items 2a to 2d</i>	1
2a*	◇	DIFFUSER/SEAT	1	2a*	◇	DIFFUSER/SEAT	1
2b*	◇	GASKET, copper	1	2b*	◇	GASKET, copper	1
2c*	◇	NEEDLE	1	2c*	◇	NEEDLE	1
2d*	166969	TIP GASKET	1	2d*	166969	TIP GASKET	1
6	235482	FLUID HOUSING, two finger	1	6	235483	FLUID HOUSING, four finger	1
8	187985	TRIGGER, two finger	1	8	188127	TRIGGER, four finger	1
9	102207	SETSCREW, 1/4-20	1	9	102207	SETSCREW, 1/4-20	1
10	187965	PIVOT PIN	1	10	187965	PIVOT PIN	1
11	235471	GUN HANDLE	1	11	235471	GUN HANDLE	1
12	203953	SCREW, hex washer hd, 10-24	1	12	203953	SCREW, hex washer hd, 10-24	1
13	107091	SCREW, 1/4-20	2	13	107091	SCREW, 1/4-20	2
14▲	187987	WARNING TAG <i>not shown</i>	1	14▲	187987	WARNING TAG <i>not shown</i>	1
15▲	222385	WARNING CARD <i>not shown</i>	1	15▲	222385	WARNING CARD <i>not shown</i>	1

Parts / Pièces / Onderdelen / Teile

235462, C

Fine-Finish (non-reversing) DripLess™ Tip Guard; 2-finger trigger. *Includes 1 to 15.*

Ref No.	Part No.	Description	Qty.
1	220247	FINE FINISH TIP GUARD	1
2	235475	NEEDLE KIT <i>Includes items 2a to 2d</i>	1
2a†	◇	PRE-ORIFICE SEAT	1
2b†	◇	GASKET, copper	1
2c†	◇	NEEDLE	1
2d†	162863	TIP GASKET	1
6	235482	FLUID HOUSING, two finger	1
8	187985	TRIGGER, two finger	1
9	102207	SETSCREW, 1/4-20	1
10	187965	PIVOT PIN	1
11	235471	GUN HANDLE	1
12	203953	SCREW, hex washer hd, 10-24	1
13	107091	SCREW, 1/4-20	2
14▲	187987	WARNING TAG <i>not shown</i>	1
15▲	222385	WARNING CARD <i>not shown</i>	1

243283, A

HandTite™ Tip Guard; 2-finger trigger. *Includes 2 to 23.*

Ref No.	Part No.	Description	Qty.
2	235474	NEEDLE KIT <i>Includes items 2a to 2c</i>	1
2a*	◇	DIFFUSER/SEAT	1
2b*	◇	GASKET, copper	1
2c*	◇	NEEDLE	1
6	235482	FLUID HOUSING, two finger	1
8	187985	TRIGGER, two finger	1
9	102207	SETSCREW, 1/4-20	1
10	187965	PIVOT PIN	1
11	235471	GUN HANDLE	1
12	203953	SCREW, hex washer hd, 10-24	1
13	107091	SCREW, 1/4-20	2
14▲	187987	WARNING TAG <i>not shown</i>	1
15▲	222385	WARNING CARD <i>not shown</i>	1
18▲	187346	WARNING SHEET <i>not shown</i>	1
21	243161	HandTite™ Tip Guard	1
22	286517	RAC 5 SwitchTip, Size 517	1
23	243281	OneSeal™ (5-pack)	1

The following information applies to all parts lists:

* *Included in Repair Kit 235474, purchased separately. Kit includes installation tool.*

† *Included in Repair Kit 235475, purchased separately. Kit includes installation tool.*

◇ *Part not sold separately*

▲ *Replacement Danger and Warning labels, tags and cards are available at no cost.*

235464, C

Heavy Duty RAC® tip; 2-finger fluid housing, 2-finger trigger. *Includes 2 to 20.*

Ref No.	Part No.	Description	Qty.
2	235474	NEEDLE KIT <i>Includes items 2a to 2c</i>	1
2a*	◇	DIFFUSER/SEAT	1
2b*	◇	GASKET, copper	1
2c*	◇	NEEDLE	1
2d*	166969	TIP GASKET	1
6	235482	FLUID HOUSING, two finger	1
8	187985	TRIGGER, two finger	1
9	102207	SETSCREW, 1/4-20	1
10	187965	PIVOT PIN	1
11	235471	GUN HANDLE	1
12	203953	SCREW, hex washer hd, 10-24	1
13	107091	SCREW, 1/4-20	2
14▲	187987	WARNING TAG <i>not shown</i>	1
15▲	222385	WARNING CARD <i>not shown</i>	1
16	222674	HEAVY DUTY RAC tip assembly	1
17	GHD617	HEAVY DUTY SwitchTip, Size 617	1
19		GASKET, tip guard	1
19a	221176	GASKET, black (5 pack); includes 20 Use with water based coatings	1
19b	224081	GASKET, yellow (5 pack); includes 20 Use with solvent based coatings	1
20	◇	SEAT, cylinder; included with 19	1

Ref No.	Part No.	Description	Qty.
---------	----------	-------------	------

238591, A

Heavy Duty RAC® tip; 4-finger trigger. *Includes 2 to 20.*

2	235474	NEEDLE KIT <i>Includes items 2a to 2c</i>	1
2a*	◇	DIFFUSER/SEAT	1
2b*	◇	GASKET, copper	1
2c*	◇	NEEDLE	1
2d*	166969	TIP GASKET	1
6	235483	FLUID HOUSING, four finger	1
8	188127	TRIGGER, four finger	1
9	102207	SETSCREW, 1/4-20	1
10	187965	PIVOT PIN	1
11	235471	GUN HANDLE	1
12	203953	SCREW, hex washer hd, 10-24	1
13	107091	SCREW, 1/4-20	2
14▲	187987	WARNING TAG <i>not shown</i>	1
15▲	222385	WARNING CARD <i>not shown</i>	1
16	237162	HEAVY DUTY RAC tip assembly	1
17	GHD619	HEAVY DUTY SwitchTip, Size 619	1
19		GASKET, tip guard	1
19a	221176	GASKET, black (5 pack); includes 20 Use with water based coatings	1
19b	224081	GASKET, yellow (5 pack); includes 20 Use with solvent based coatings	1
20	◇	SEAT, cylinder	1

Graco Standard Warranty

Garantie Graco standard

Graco-standaardgarantie

Graco Standardgarantie

Graco warrants all equipment referenced in this document which is manufactured by Graco and bearing its name to be free from defects in material and workmanship on the date of sale by an authorized Graco distributor to the original purchaser for use. With the exception of any special, extended, or limited warranty published by Graco, Graco will, for a period of twelve months from the date of sale, repair or replace any part of the equipment determined by Graco to be defective. This warranty applies only when the equipment is installed, operated and maintained in accordance with Graco's written recommendations.

This warranty does not cover, and Graco shall not be liable for general wear and tear, or any malfunction, damage or wear caused by faulty installation, misapplication, abrasion, corrosion, inadequate or improper maintenance, negligence, accident, tampering, or substitution of non-Graco component parts. Nor shall Graco be liable for malfunction, damage or wear caused by the incompatibility of Graco equipment with structures, accessories, equipment or materials not supplied by Graco, or the improper design, manufacture, installation, operation or maintenance of structures, accessories, equipment or materials not supplied by Graco.

This warranty is conditioned upon the prepaid return of the equipment claimed to be defective to an authorized Graco distributor for verification of the claimed defect. If the claimed defect is verified, Graco will repair or replace free of charge any defective parts. The equipment will be returned to the original purchaser transportation prepaid. If inspection of the equipment does not disclose any defect in material or workmanship, repairs will be made at a reasonable charge, which charges may include the costs of parts, labor, and transportation.

THIS WARRANTY IS EXCLUSIVE, AND IS IN LIEU OF ANY OTHER WARRANTIES, EXPRESS OR IMPLIED, INCLUDING BUT NOT LIMITED TO WARRANTY OF MERCHANTABILITY OR WARRANTY OF FITNESS FOR A PARTICULAR PURPOSE.

Graco's sole obligation and buyer's sole remedy for any breach of warranty shall be as set forth above. The buyer agrees that no other remedy (including, but not limited to, incidental or consequential damages for lost profits, lost sales, injury to person or property, or any other incidental or consequential loss) shall be available. Any action for breach of warranty must be brought within two (2) years of the date of sale.

GRACO MAKES NO WARRANTY, AND DISCLAIMS ALL IMPLIED WARRANTIES OF MERCHANTABILITY AND FITNESS FOR A PARTICULAR PURPOSE, IN CONNECTION WITH ACCESSORIES, EQUIPMENT, MATERIALS OR COMPONENTS SOLD BUT NOT MANUFACTURED BY GRACO. These items sold, but not manufactured by Graco (such as electric motors, switches, hose, etc.), are subject to the warranty, if any, of their manufacturer. Graco will provide purchaser with reasonable assistance in making any claim for breach of these warranties.

In no event will Graco be liable for indirect, incidental, special or consequential damages resulting from Graco supplying equipment hereunder, or the furnishing, performance, or use of any products or other goods sold hereto, whether due to a breach of contract, breach of warranty, the negligence of Graco, or otherwise.

À L'ATTENTION DES CLIENTS DE GRACO PARLANT FRANCAIS

Les parties reconnaissent avoir convenu que la rédaction du présente document sera en Anglais, ainsi que tous documents, avis et procédures judiciaires exécutés, donnés ou intentés à la suite de ou en rapport, directement ou indirectement, avec les procédures concernées.

VOOR NEDERLANDSTALIGE GRACO-KLANTEN

The Parties acknowledge that they have required that the present document, as well as all documents, notices and legal proceedings entered into, given or instituted pursuant hereto or relating directly or indirectly hereto, be drawn up in English. De partijen zijn ermee akkoord dat het onderhavige document, evenals alle documenten, berichtgevingen en wettelijke procedures die hierin zijn vastgelegd, aangegeven of die hieruit voortvloeien, hetzij rechtstreeks, hetzij indirect, in het Engels worden opgesteld.

FÜR DEUTSCHSPRACHIGE GRACO-KUNDEN

Die Parteien bestätigen, daß sie festgelegt haben, daß das vorliegende Dokument sowie alle anderen Dokumente, Mitteilungen und Gerichtsverfahren, die im Zusammenhang damit erstellt, verteilt oder eingeleitet werden, oder sich direkt oder indirekt darauf beziehen, in englischer Sprache sein sollen.

ADDITIONAL WARRANTY COVERAGE / AVENANT DE GARANTIE AANVULLENDE GARANTIEDEKING / ZUSÄTZLICHER GARANTIEUMFANG

Graco does provide extended warranty and wear warranty for products described in the "Graco Contractor Equipment Warranty Program".

Graco accorde une garantie étendue et se porte garant des produits décrits dans le "Programme de garantie d'équipements des fournisseurs Graco".

Graco biedt verlengde garantie en slijtagegarantie op producten die zijn beschreven in het "Graco-garantieprogramma voor Contractor-apparatuur".

Graco gewährt eine erweiterte Garantie und eine Verschleißgarantie für die im "Garantieprogramm für Graco-Contractorgeräte" beschriebenen Produkte.

Technical Data / Caractéristiques techniques Technische gegevens / Technische Daten

Category	Data
Maximum working pressure	5000 psi (345 bar, 34.5 MPa)
Fluid orifice size	235462: 0.037 in. (0.94 mm) All others: 0.090 in. (2.3 mm)
Wetted parts	Stainless steel, Polyethylene, Polyurethane, Nylon, PTFE
Weight	18 oz (510 g)
Inlet	1/4 npsm(m)
Maximum material temperature	120°F (50°C)
* Sound pressure level	78 dBa
* Sound power level	87 dBa

* Measured while spraying waterbase paint – gravity 1.36 through a 517 tip at 3000 psi (207 bar, 20.7 MPa) per ISO 3744.

* Mesures effectuées lors d'une pulvérisation de peinture à l'eau – gravité 1,36 avec une buse de 517 à une pression de 3000 psi (207 bar, 20,7 MPa) selon la norme ISO 3744.

* Gemeten tijdens het spuiten met verf op waterbasis met een soortelijk gewicht van 1,36 en een 517 tip met een druk van 3000 psi (207 bar, 20,7 MPa) conform ISO 3744.

* Gemessen beim Spritzen von Lack auf Wasserbasis – Gravität 1,36 durch eine 517er-Düse bei 207 bar (20,7 MPa) nach ISO 3744.

TO PLACE AN ORDER OR FOR SERVICE, contact your Graco distributor,
or call 1-800-690-2894 to identify the nearest distributor.

POUR PASSER COMMANDE OU DEMANDER UNE PRESTATION D'ENTRETIEN, contactez votre distributeur Graco
NEEM VOOR BESTELLINGEN OF VOOR ONDERSTEUNING contact op met uw Graco-leverancier,
of bel 1-800-690-2894 voor de gegevens van de dichtstbijzijnde leverancier.

FÜR EINE BESTELLUNG ODER EINE SERVICE-ANFORDERUNG nehmen Sie bitte mit Ihrem Graco-Händler Kontakt auf,
oder rufen Sie die Nummer 1-800-690-2894, um zu erfahren, wo sich der nächstgelegene Händler befindet.

All written and visual data contained in this document reflects the latest product information available at the time of publication. Graco reserves the right to make changes at any time without notice.

Toutes les données écrites et visuelles figurant dans ce document reflètent les toutes dernières informations disponibles au moment de sa publication. Graco se réserve le droit de procéder à des modifications à tout moment sans avis préalable.

Alle geschreven gegevens en afbeeldingen in dit document zijn een weergave van de meest recente informatie die beschikbaar was op het tijdstip van publicatie. Graco behoudt zich het recht voor op elk moment zonder voorafgaand bericht wijzigingen aan te brengen.

Die in dieser Dokumentation enthaltenen Daten entsprechen dem Stand zum Zeitpunkt der Drucklegung. Änderungen vorbehalten.

Sales Offices: Minneapolis

International Offices: Belgium, Korea, Hong Kong, Japan

Bureaux des ventes: Minneapolis

Bureaux Internationaux: Belgique, Corée, Hong-Kong, Japon

Verkoopkantoren: Minneapolis

Internationale Bureaus: België, Korea, Hong Kong, Japan

Verkaufsstellen: Minneapolis

Internationale Büros: Belgien; Korea, Hong Kong, Japan

**GRACO N.V.; Industrieterrein — Oude Bunders;
Slakweidestraat 31, 3630 Maasmechelen, Belgium
Tel.: 32 89 770 700 – Fax: 32 89 770 777**

<http://www.graco.com>

PRINTED IN USA 309092 11/2001 Revised 08/2004

IMPRIMÉ AUX É.-U. 309092 11/2001 Revisado 08/2004

GEDRUKT IN DE VS 309092 11/2001 Herzien 08/2004

PRINTED IN USA 309092 11/2001 Revised 08/2004